

COLLECTORS NO. 40012

Chippendale Night Stand

Circa 1750-1790



A typical simple table that might have been found in the sleeping salon of a home in the mid 1700's. The single drawer suggests a place to put personal articles and the shelf to store the Bible which might have been read before retiring. The large space below the drawer might have held other books or a place to store a china vase. The lid or small shelf at the top might have been used to hold a candle. The single bracket feet and solid sides indicate the fact that probably this piece was made by local craftsmen and for use not as a true decorator piece of furniture but rather more of a utilitarian table.



AUTHENTIC REPRODUCTIONS IN MINIATURE

The X-ACTO® House of Miniatures Collectors Series of furniture and accessories have all been carefully researched by specialists through major museum and library collections to assure the highest quality of authenticity in reproduction. Details are extraordinarily accurate to satisfy the most discriminating miniaturist.

Every item in the line is an authentic reproduction in miniature of regular-size furniture created by master craftsmen during the Colonial period, precision scaled, one inch to one foot.

All wood parts are machined to assure accurate and precise acceptance of each piece by another.

The rooms illustrated have been completed using standard X-ACTO® HOUSE OF MINIATURES products. All individual components are available.

For a complete catalog of the X-ACTO® HOUSE OF MINIATURES furniture line and accessories, write to:

X-ACTO/ THE HOUSE OF MINIATURES
Dept. KIT 45-35 Van Dam Street, Long Island
City, New York 11101.

Please include \$1.00 for postage and handling.

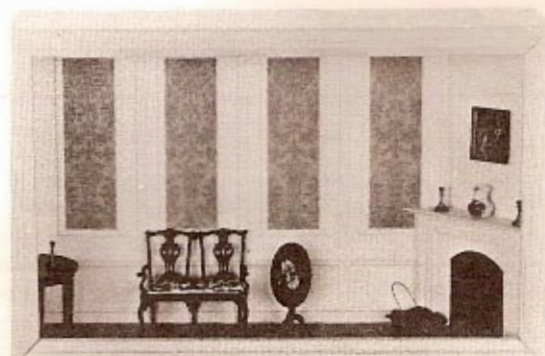
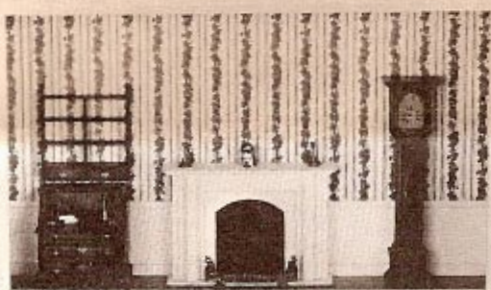

X-ACTO®

INTRODUCTION

INSTRUCTIONS BEFORE STARTING

before starting

A. Identify and account for each part by placing it on the **LAYOUT SHEET** (Page 2). This will indicate, at a glance, whether any parts are missing. **(See instructions at bottom of last sheet to order missing parts.)**

B. The LAYOUT SHEET contains a hardware check list. Use this to identify and account for all hardware that comes with the kit.

sanding

NOTE: When using sandpaper, remember that the higher the grit number, the finer the finish.

A. One sanding method that has proved successful is the use of a sanding platform. Tape a sheet of sandpaper of the proper grit size to a hard flat surface such as a table top or wood block. Press down **lightly** and move the piece to be sanded **in the same direction** as the wood grain until the surface is smooth. **Take care not to round any edges or corners of the pieces.**

B. Before assembly, sand all the outer surfaces of individual parts with 220 grit sandpaper, or finer, paying particular attention to edges that will be exposed after assembly. After sanding each piece thoroughly, finish sanding with 400 grit sandpaper. Remember, your final stained finish will only be as smooth as the surface under it.

hardware

A. All hardware to complete this kit is provided. Installation holes for all hardware must be made in accordance with the **ASSEMBLY** instructions that follow. Use the **DETAIL VIEWS** (Page 3) for hole locations.

B. Do not force handle into holes in handle plate. If a hole is too small, enlarge it slightly with a small knife or needle file.

C. Do not install brass hardware until final finishing has been done to avoid staining hardware.

gluing

A. Glue should be applied in small amounts to both surfaces being joined. On end cuts, it may be necessary to apply a second coat of glue before joining the parts.

B. To ensure a tight fit, squeeze excess glue out of the joints by holding glued parts together with either clamps, rubber bands or by placing weights on the parts.

C. Wipe off excess glue promptly with a damp cloth.

D. Be sure a glued assembly has dried thoroughly before adding any more parts.

tools and materials

A. The following tools **will be helpful** in constructing this kit:

1. Knife, X-ACTO No. 1, with Blade, X-ACTO No. 11
2. Tweezer, X-ACTO No. 36
3. One - inch Sander, X- ACTO No. 41
4. Two-inch Sander, X-ACTO No. 42
5. Large Clamp, X-ACTO No. 4004
6. Small Clamp, X-ACTO No. 4003
7. Swiss Needle File Set, X-ACTO No. 60S
8. Professional Finishing Kit, X-ACTO No. 43801
9. Power Sprayer, X-ACTO No. 43561

B. The following materials **will be needed** to construct this kit:

1. Straight pins or artist's push pins
2. Rubber bands
3. Waxed paper
4. Sandpaper - 220,320,and 400 grit
5. Steel wool - Grade 000
6. Masking tape
7. Ruler
8. Wood stain of your choice. **(See Note)**
9. Glaze stain of your choice. **(See Note)**
10. Lacquer or varnish of your choice. **(See Note)**
11. White glue, or any good wood glue. **(See Note)**
12. Sealer **(See Note)**
13. Small Artist's Brush

NOTE: The X-ACTO No. 43801 Professional Finishing Kit will produce the authentic Mahogany finish of the period in which the original furniture was produced. Base stain, glaze stain, lacquer or varnish, sealer and glue are required only if the X-ACTO Professional Finishing Kit is not used.

pre-assembly

A. After sanding, check the proper location and fit of each part by assembling parts loosely, without gluing. Use the **DETAIL VIEWS** (Page 3) as a guide.

B. Parts can be held together to check proper fit with rubber bands or masking tape.

C. All parts for X-ACTO kits are made on precision milling machines, using rabbet and dado joints. Parts will fit together snugly with very little adjustments required. When adjustments are required, sand or file to fit.

LAYOUT SHEET

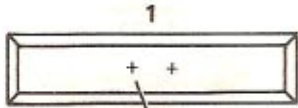

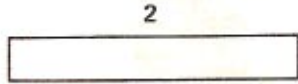

positioning points
for handle plates

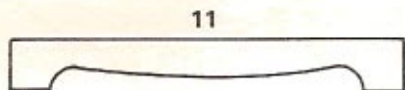
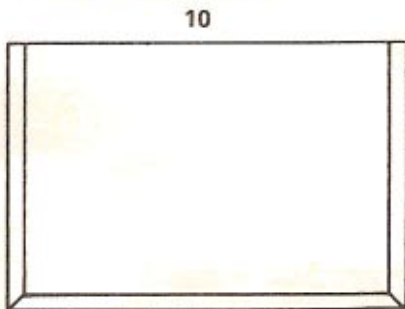
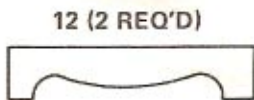
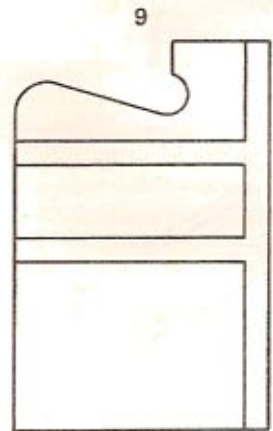
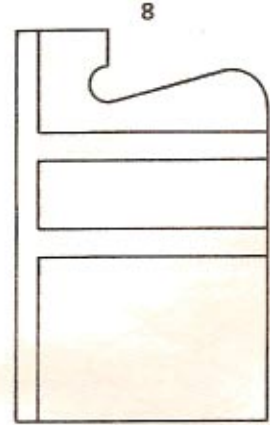
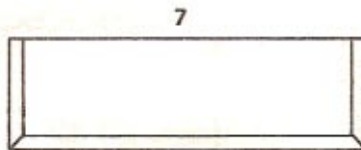
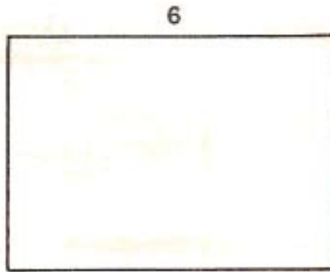
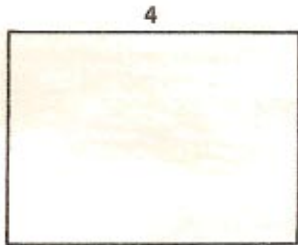

3 (2 REQ'D)



| HARDWARE CHECK LIST | | |
|---------------------|---|-----|
| DESCRIPTION | VISUAL DESCRIPTION | QTY |
| HANDLE |  | 1 |
| HANDLE PLATE |  | 1 |

DETAIL VIEWS

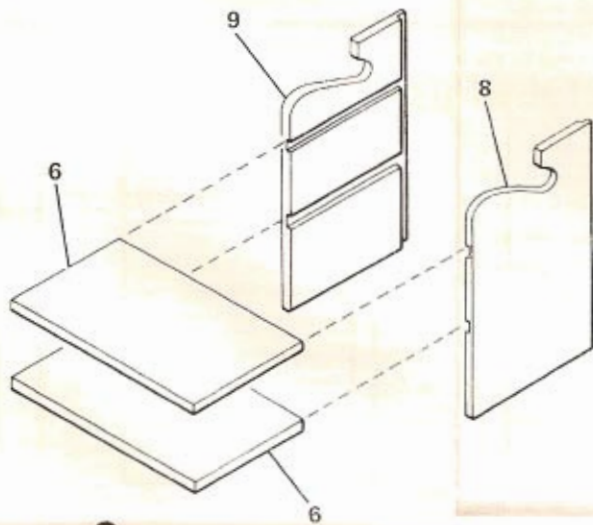

DETAIL A

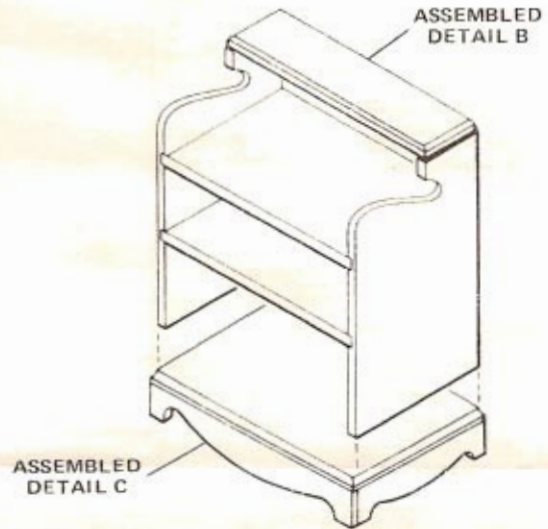

DETAIL D

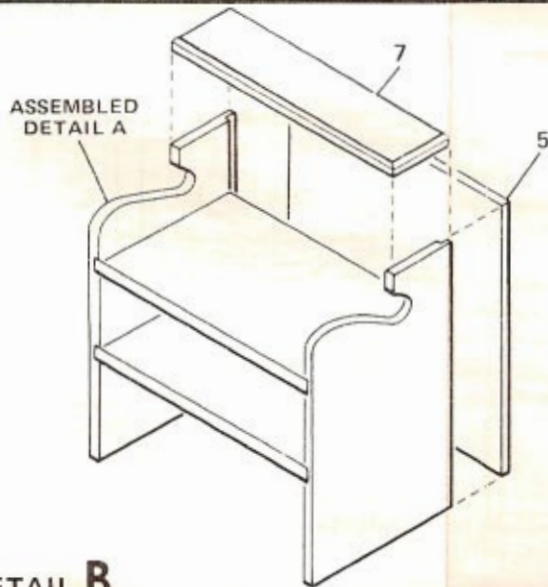

DETAIL B

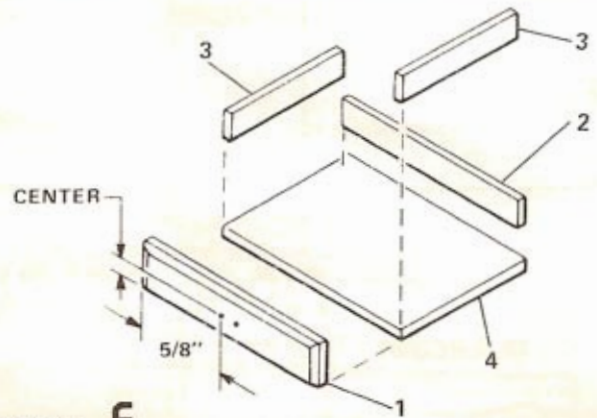

DETAIL E

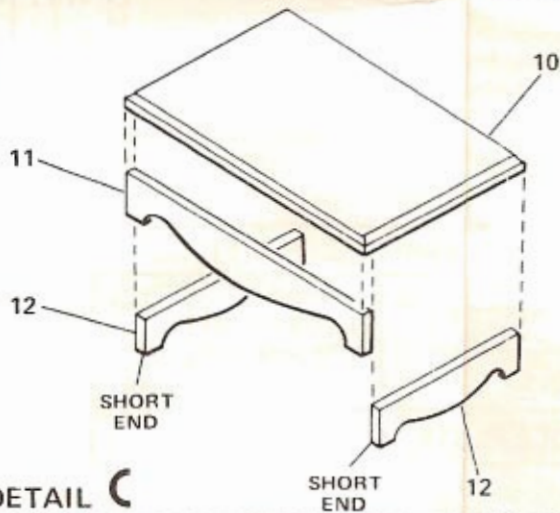

DETAIL C

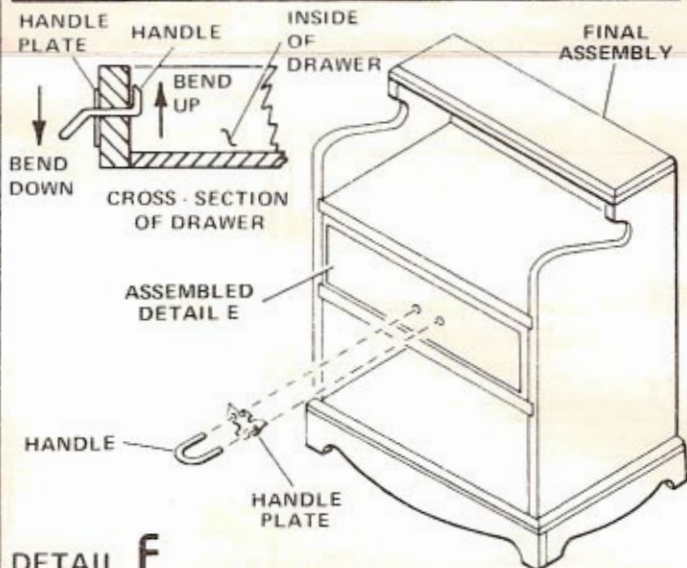

DETAIL F

ASSEMBLY

A. Before starting to assemble your kit, study all illustrations and instructions carefully. Be certain you understand each step before proceeding to the next one.

B. Follow the sequence of steps in the order they are presented. **Do not** skip steps or take short cuts.

C. Refer to **ALIGNMENT** (Page 5) for the pattern to be used to align the frame. When gluing parts together use a flat toothpick or similar tool to apply a small amount of glue to the parts to be joined. Remove any excess glue promptly with a damp cloth. **Remember to let each glued assembly dry thoroughly before adding the next part.**

D. The Professional Finishing Kit, X-ACTO No. 43801, will produce the authentic Mahogany finish of this period and contains a **matching tinted glue**, which is recommended for assembly of this kit. The **tinted glue** is of furniture grade quality, equivalent to that used by professional cabinet makers and its use will avoid the appearance of a glue line at each joint.

E. Begin assembly of the **frame** (see **DETAIL A**, page 3) as follows:

1. Glue two shelves (part no. 6) into grooves in sides (parts no. 8 and 9). Align the parts face down on the **alignment pattern** (see **ALIGNMENT**, page 5).

2. Press the back piece (part no. 5) into place, but **do not** glue. This will help align the sides and ensure shelves are flush across the front.

3. Use clamps or several rubber bands to hold parts in place until glue sets. (Follow the instructions for the glue being used for the proper setting time.)

F. Continue assembly of the frame (see **DETAIL B**, page 3) as follows:

1. Glue back (part no. 5) and top (part no. 7) to assembled Detail A. Make sure that rear edge of top is flush with rear edges of sides and back, and that the top is centered over sides.

2. Secure parts in position with clamps or rubber bands and put assembly aside until glue has set.

G. Assemble **base** (see **DETAIL C**, page 3) as follows:

1. Glue two side supports (part no. 12) to the base platform (part no. 10). Ensure supports are flush with the side and back edges of the platform and that the short end of the supports are toward the front.

2. Glue front support (part no. 11) flush with front edge of base platform and side supports.

H. Complete assembly of frame (see **DETAIL D**, page 3) by gluing assembled Detail B to assembled Detail C. Ensure base is properly centered and flush with back edge of Detail B. Lay assembly **face up** on a flat surface and allow glue to set.

I. Assemble **drawer** (see **DETAIL E**, page 3) as follows:

1. Using dimensions shown, position a handle plate on the drawer front (part no. 1). Mark the position of the handle holes using a straight pin or artist's push pin.

2. Using the straight pin or push pin, make holes through drawer front at the marked positions.

3. Glue two drawer sides (part no. 3) and drawer back (part no. 2) to drawer bottom (part no. 4).

4. Glue drawer front (part no. 1) to front edges of drawer sides and bottom.

J. You have now completed assembly of your furniture, except for the installation of brass hardware. Refer now to **FINAL FINISHING** for final finishing instructions. **Then continue with ASSEMBLY paragraph K**, for installation of brass hardware.

NOTE: For authenticity, when finishing drawer, finish only the drawer front.

K. Install **brass hardware** (see **DETAIL F**, page 3) as follows:

1. Press handle through holes in handle plate, apply a **small** amount of glue to the back of handle plate and insert handle ends through the holes in drawer front.

2. Bend up the ends of the handle at rear of drawer front and bend down front of handle. (see **DETAIL F**, page 3)

L. You have now completed assembly of your furniture. The completed piece should look like that shown in **DETAIL F** (page 3).

FINAL FINISHING

In order to ensure that your piece is stained and highlighted in the tones of the period in which the original furniture was produced, we recommend that **X-ACTO Professional Finishing Kit, No. 43801** be used. The following method is used by professional furniture makers, and, if done properly, will result in museum quality.

A. After assembly is completed and the glue has set, **lightly** sand all joint areas to remove excess glue, using 220 grit sandpaper or finer. Moisten a cloth slightly and rub the dampened cloth over the entire wood surface to raise the grain. When all signs of moisture have gone from the wood, resand using a 320 to 400 grit sandpaper.

B. With a small brush, apply a light sealer coat to all edges and end grains. Use the side of the brush rather than the tip, in a wiping motion, so that the sealer does not touch other surfaces. Sealing the edge and end grains will prevent the subsequent stains from penetrating these areas as deeply, resulting in a more uniform stain on all parts.

NOTE: If the X-ACTO Finishing Kit (which contains a high quality sealer) is not used, thinned varnish or lacquer can be used for this purpose.

C. To match the color of furniture of this period apply **X-ACTO Base Stain** or mahogany or cherry stain of your choice with a brush or cloth over the entire wood surface. Immediately wipe off all excess stain leaving an even color on the surface. Allow to dry.

D. Apply a thin coat of **X-ACTO Sealer** or any commercial wood sealer over the base stain. This can be applied with either a brush or with the **X-ACTO Power Sprayer**. Make sure there are no drip marks present. Allow the sealer to dry for at least 6 hours.

X-ACTO POWER SPRAYER No. 43561 can be used to apply sealer, top coat, and paints for outstanding results. This spray ensures application of an even coat, especially on intricate and flat surfaces, and it is highly recommended for finishing your furniture.

E. Lightly go over all surfaces with Grade 000 steel wool until they are smooth to the touch.

F. "**Highlighting**" is a technique of creating light and dark areas and is accomplished by applying the **X-ACTO Glaze Stain** or any commercial glaze stain of your choice (Van Dyck Brown is the color recommended) and then toning by rubbing off the glaze in certain areas, exposing the base stain. In order to "highlight", apply a dark glaze with a brush or rag over the entire piece of furniture. As soon as you have applied this glaze, wipe off the excess. Blend tones of base color and glaze stain by using a piece of soft cloth. There should never be a sharp line of dark color to light color, but rather a smooth blending effect. Lighten the middle surface of the wood, but do not lighten the entire surface. The "**highlighting**" technique will produce museum quality miniature furniture.

G. After the glaze stain has dried for 24 hours, thoroughly and briskly wipe all surfaces with a clean cloth until you are satisfied with the appearance. Apply the **X-ACTO Top Coat** or a coat of lacquer or varnish, with a brush, an airbrush, or with the **X-ACTO Power Sprayer**. Apply two or more top coats with light buffing between coats using Grade 000 steel wool. After each steel wool rubbing make sure all steel wool "dust" is removed thoroughly. (**Continue with ASSEMBLY starting with paragraph K.**)

ALIGNMENT

A. Tape this sheet to a smooth, flat surface. Then tape sheet of waxed paper to the pattern so that any excess glue at the joint will not stick to the pattern, making it difficult to remove the completed assembly.

B. Use the alignment pattern shown here to position the indicated parts properly and to hold them in alignment while drying.

alignment pattern

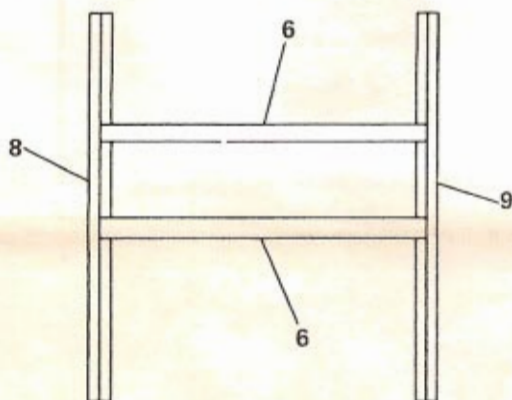
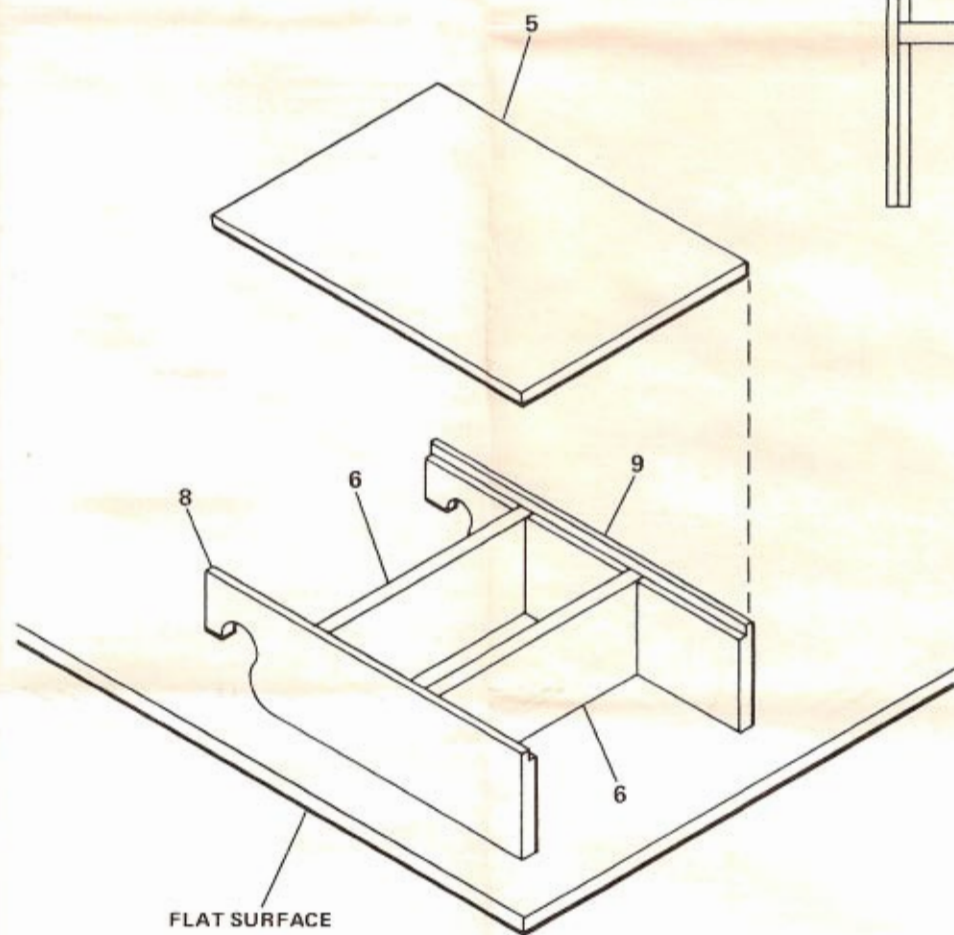

Every effort has been made to insure the completeness of this KIT—however, should any parts be missing, write directly to:
X-ACTO/THE HOUSE OF MINIATURES
45-35 Van Dam Street
Long Island City, N.Y. 11101



When ordering missing parts, please Print your name and address plainly. State the missing PART NO. (See LAYOUT SHEET, page 2), KIT NO. 40012 and the Kit Name, "CHIPPENDALE NIGHT STAND".