

COLLECTORS NO. 40013



Queen Anne
Candle Stand
Circa 1725-1760

Queen Anne, second daughter of James II, ruled England from 1702 until 1714. The furniture style that bears her name, however, covers a period of forty years. The Queen Anne style, developed during this age of flourishing craftsmanship, brought American furniture of greater lightness and grace and a new concept of comfort. Convenience was added by many small tables with turnover hinged tops for tea, games and other purposes. Furniture was less massive than that made in previous centuries.

In America, the furniture was made in a Queen Anne style from about 1725-1760. The American versions were smaller scale than older styles but more substantial than their English counterparts. Veneer was less used here. The fashionable wood was walnut, followed by the native hardwoods, maple and cherry, and then mahogany, which became most important after 1720.

There is a distinction between "candle tables" and "candle stands" as stands were for the specific use to handle the only source of light for the room that being candles.

Kerosene was not available until the mid 1800's and thus many candle stands were found throughout homes of this period. When you walked through the home after dark, you would carry a candle and set it on one of these stands which were usually over three feet tall. Found in all rooms usually next to chairs, sofas, beds, dry sinks and working areas.

ASSEMBLY AND FINISHING INSTRUCTIONS



AUTHENTIC REPRODUCTIONS IN MINIATURE.

The X-ACTO® House of Miniatures Collectors Series® of furniture and accessories have all been carefully researched by specialists through major museum and library collections to assure the highest quality of authenticity in reproduction. Details are extraordinarily accurate to satisfy the most discriminating miniaturist.

All wood parts are machined to assure accurate and precise acceptance of each piece by another.

For a complete catalog of the X-ACTO® HOUSE OF MINIATURES furniture line and accessories, write to:

X-ACTO® THE HOUSE OF MINIATURES Dept. KIT
45-35 Van Dam Street
Long Island City,
New York 11101

Please include \$2.00 for postage and handling.

INTRODUCTION

BEFORE STARTING

Identify and account for each part by placing it on the Layout Sheet (make sure the correct layout sheet is used when working on multi-kit Instruction Sheets). Should any parts be missing, send a post card to:

X-ACTO/The House of Miniatures
45-35 Van Dam Street
Long Island City, N.Y. 11101

Please print Name, Address, Part Number (Number from Layout Sheet) and Kit Name and Number on card when ordering.

SANDING

Before assembly, sand all the outer surfaces of individual parts with 220 grit sandpaper, or finer, sanded in the same direction as the wood grain until the surface is smooth. Take care not to round any edges or corners of the pieces. Finish sanding with 280 grit sandpaper.

PRE-ASSEMBLY

A. After sanding, check the proper location and fit of each part by assembling parts loosely, without gluing. Use the **DETAIL VIEWS** as a guide.

B. All parts for X-ACTO kits are made on precision milling machines. When adjustments are required, sand to fit.

TOOLS AND MATERIALS

A. The following tools will be helpful in constructing this kit:

1. Two-inch Sander, X-ACTO No. 7042
2. Small Clamp, X-ACTO No. 7003
3. X-ACTO Professional Finishing Kit (or equivalent See note)

B. The following materials will be needed to construct this kit:

1. X-ACTO Tinted Glue (see note)
2. Sandpaper - 220 and 280 grit
3. Steel Wool - Grade 0000
4. Small Artist's Brush

NOTE: The X-ACTO tinted glue is matched to the finish used in the Professional Finishing Kit. This will produce the authentic finish of the period in which the original Furniture was produced. When not using X-ACTO glue follow manufacturer's directions.

GLUING

A. Glue should be applied in small amounts to surface being joined. When gluing dado joints apply glue to dado only.

B. To ensure a tight fit, squeeze excess glue out of the joints. Hold glued parts together with clamps, rubber bands or weights on the parts.

C. Wipe off excess glue promptly.

D. Be sure a glued assembly has dried thoroughly before adding parts.

FINISHING

The X-ACTO Professional Finishing Kit enables you to finish your furniture by the same process used by the professional furniture maker. The end result is what is important — there are easier methods, but none that will give the quality results that this process will. If you use a finish other than X-ACTO's, refer to the manufacturer's directions.

Detail Views

Kit 40013

Layout

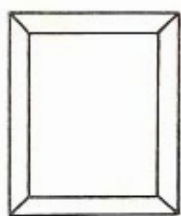

23



33



20



24



26



26



26

Step 1

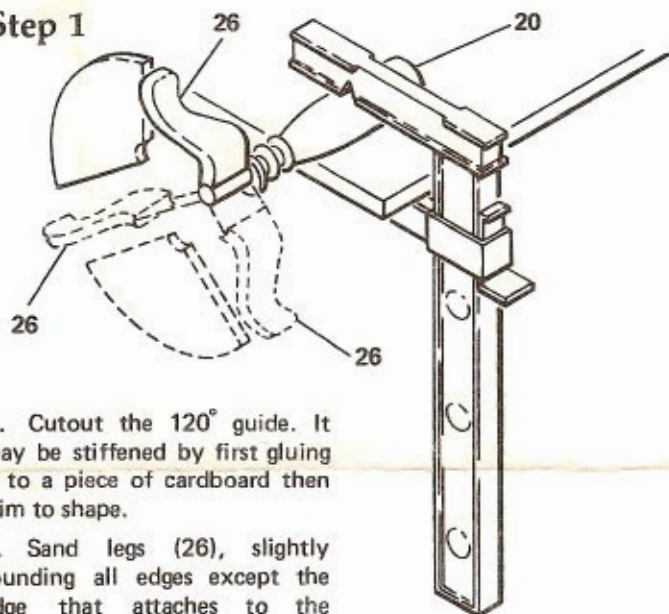

A. Cutout the 120° guide. It may be stiffened by first gluing it to a piece of cardboard then trim to shape.

B. Sand legs (26), slightly rounding all edges except the edge that attaches to the pedestal.

C. Clamp or tape the pedestal (20) to a flat surface and glue legs in place. Allow the glue to set on first leg, rotate the pedestal and use guide for proper spacing.



120°

Step 2

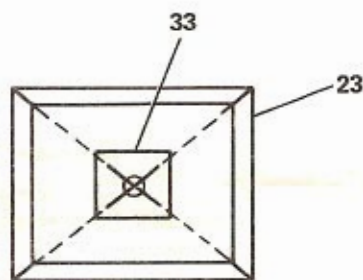

A. Locate center of top (23). Contoured edge should be towards you.

B. Glue block (33) so it is centered and square with edges of (23).

C. Glue column (24) into the hole in the top block (33). Be certain that it is straight and allow glue to set.

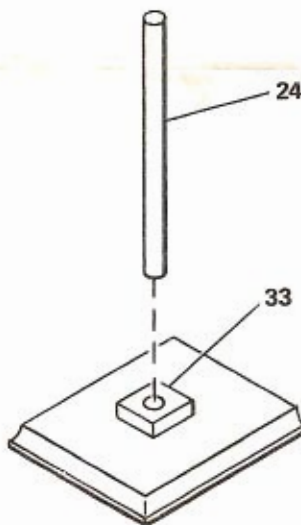

Step 3

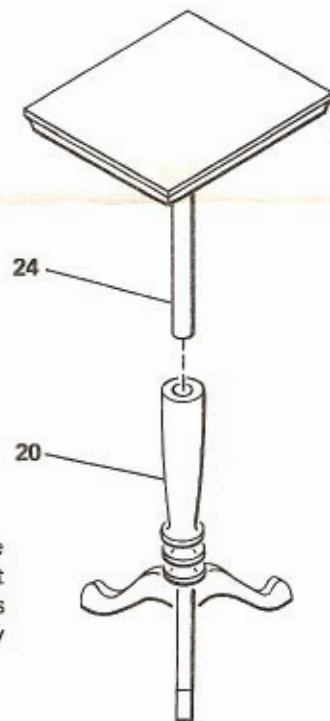

A. Glue column (24) into hole in pedestal (20). Be certain that entire assembly is straight. Legs may be adjusted by lightly sanding bottom of feet.

B. Apply final finishing.