

COLLECTORS NO. 40017
CHIPPENDALE DESK

ASSEMBLY AND
FINISHING INSTRUCTIONS

P/N CB217 REV. 1



AUTHENTIC REPRODUCTIONS IN MINIATURE



The X-ACTO® House of Miniatures® Collectors Series of furniture and accessories have all been carefully researched by specialists through major museum and library collections to assure the highest quality of authenticity in reproduction. Details are extraordinarily accurate to satisfy the most discriminating miniaturist.

Every item in the line is an authentic reproduction in miniature of regular-size furniture created by master craftsmen during the Colonial period, precision scaled, one inch to one foot.

All wood parts are machined to assure accurate and precise acceptance of each piece by another.

The rooms illustrated have been completed using standard X-ACTO® HOUSE OF MINIATURES products. All individual components are available.

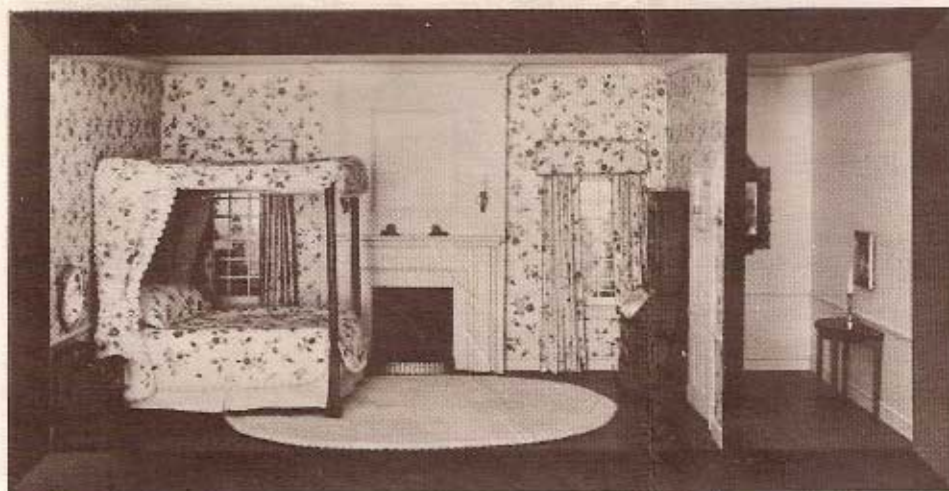

For a complete catalog of the X-ACTO® HOUSE OF MINIATURES furniture line and accessories, write to:

X-ACTO® THE HOUSE OF
MINIATURES Dept. KIT
45-35 Van Dam Street
Long Island City, New York
11101

Please include \$1.00 for
postage and handling.

X-ACTO®

INTRODUCTION

INSTRUCTIONS BEFORE STARTING

before starting

A. Identify and account for each part by placing it on the **LAYOUT SHEET** (Page 2). This will indicate, at a glance, whether any parts are missing. **(See instructions at bottom of last sheet to order missing parts.)**

B. The **LAYOUT SHEET** contains a hardware check list. Use this to identify and account for all hardware that comes with the kit.

sanding

NOTE: When using sandpaper, remember that the higher the grit number, the finer the finish.

A. One sanding method that has proved successful is the use of a sanding platform. Tape a sheet of sandpaper of the proper grit size to a hard flat surface such as a table top or wood block. Press down **lightly** and move the piece to be sanded **in the same direction** as the wood grain until the surface is smooth. **Take care not to round any edges or corners of the pieces.**

B. Before assembly, sand all the outer surfaces of individual parts with 220 grit sandpaper, or finer, paying particular attention to edges that will be exposed after assembly. After sanding each piece thoroughly, finish sanding with 400 grit sandpaper. Remember, your final stained finish will only be as smooth as the surface under it.

hardware

A. All hardware to complete this kit is provided. Installation holes for all hardware must be made in accordance with the **ASSEMBLY** instructions that follow. Use the **DETAIL VIEWS** (Page 3) for hole locations.

B. Do not force handle into holes in handle plate. If a hole is too small, enlarge it slightly with a small knife or needle file.

C. Do not install brass hardware until final finishing has been done to avoid staining hardware.

gluing

A. Glue should be applied in small amounts to both surfaces being joined. On end cuts, it may be necessary to apply a second coat of glue before joining the parts.

B. To ensure a tight fit, squeeze excess glue out of the joints by holding glued parts together with either clamps, rubber bands or by placing weights on the parts.

C. Wipe off excess glue promptly with a damp cloth.

D. Be sure a glued assembly has dried thoroughly before adding any more parts.

tools and materials

A. The following tools **will be helpful** in constructing this kit:

1. Knife, X-ACTO No. 1, with Blade, X-ACTO No. 11
2. Tweezer, X-ACTO No. 36
3. One-inch Sander X-ACTO No. 41
4. Two-inch Sander, X-ACTO No. 42
5. Large Clamp, X-ACTO No. 4004
6. Small Clamp, X-ACTO No. 4003
7. Swiss Needle File Set, X-ACTO No. 60S
8. End Snip Pliers, X-ACTO No. 1510, or Diagonal Cutting Pliers, X-ACTO No. 1505
9. Professional Finishing Kit, X-ACTO No. 43801
10. Power Sprayer, X-ACTO No. 43561
11. Jeweler's Screw Drivers, X-ACTO No. 365
12. Hand Drill, X-ACTO NO. 21D
13. Drill Bit, No. 65

B. The following materials **will be needed** to construct this kit:

1. Straight pins or artist's push pins
2. Rubber bands
3. Waxed paper
4. Sandpaper - 220, 320 and 400 grit
5. Steel wool - Grade 000
6. Masking tape
7. Ruler
8. Wood stain of your choice. **(See Note)**
9. Glaze stain of your choice. **(See Note)**
10. Lacquer or varnish of your choice. **(See Note)**
11. White glue, or any good wood glue. **(See Note)**
12. Sealer **(See Note)**
13. Small Artist's Brush

NOTE: The X-ACTO No. 43801 Professional Finishing Kit will produce the authentic Mahogany finish of the period in which the original furniture was produced. Base stain, glaze stain, lacquer or varnish, sealer and glue are required only if the X-ACTO Professional Finishing Kit is not used.

pre-assembly





A. After sanding, check the proper location and fit of each part by assembling parts loosely, without gluing. Use the **DETAIL VIEWS** (Page 3) as a guide.

B. Parts can be held together to check proper fit with rubber bands or masking tape.

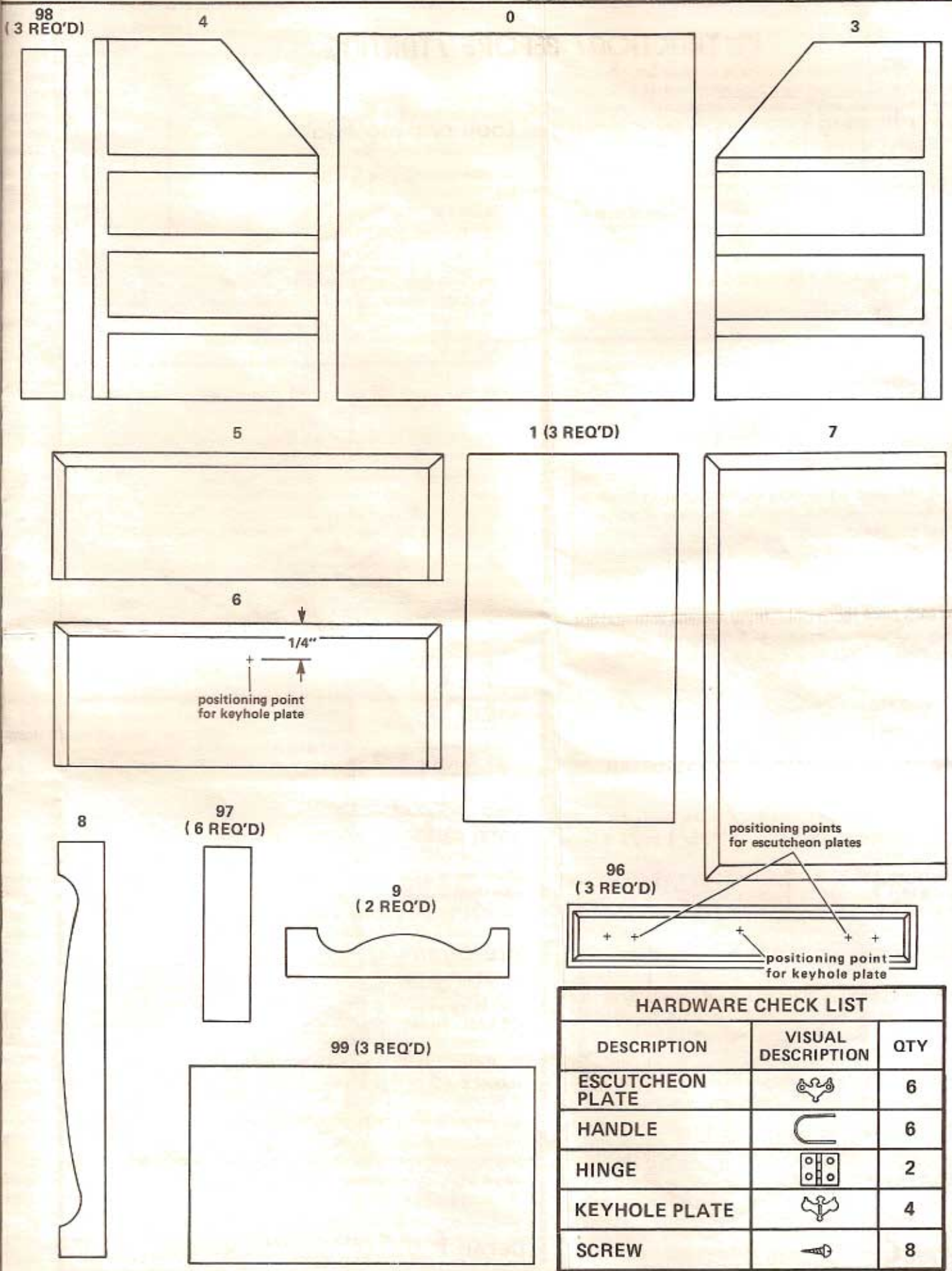
C. All parts for X-ACTO kits are made on precision milling machines, using rabbet and dado joints. Parts will fit together snugly with very little adjustments required. When adjustments are required, sand or file to fit.

LAYOUT SHEET



HARDWARE CHECK LIST		
DESCRIPTION	VISUAL DESCRIPTION	QTY
ESCUTCHEON PLATE		6
HANDLE		6
HINGE		2
KEYHOLE PLATE		4
SCREW		8

DETAIL VIEWS

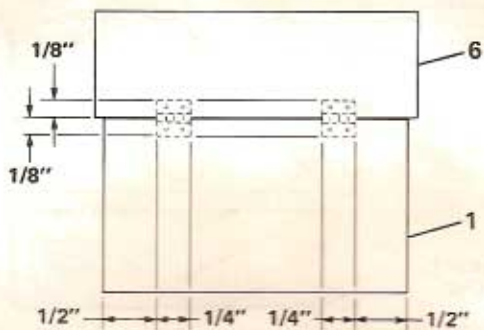

DETAIL A

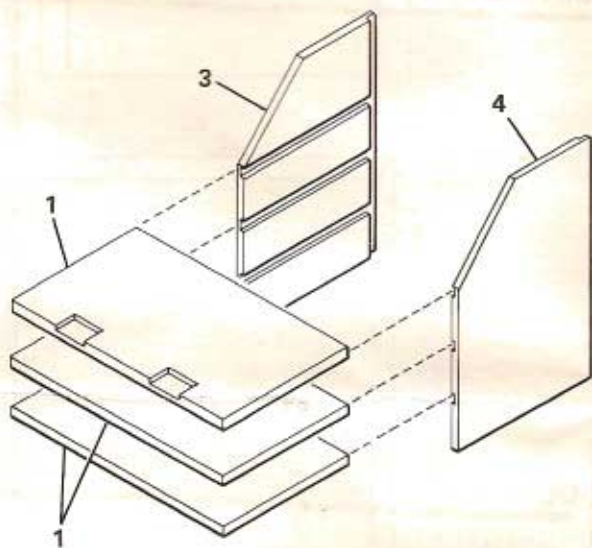

DETAIL B

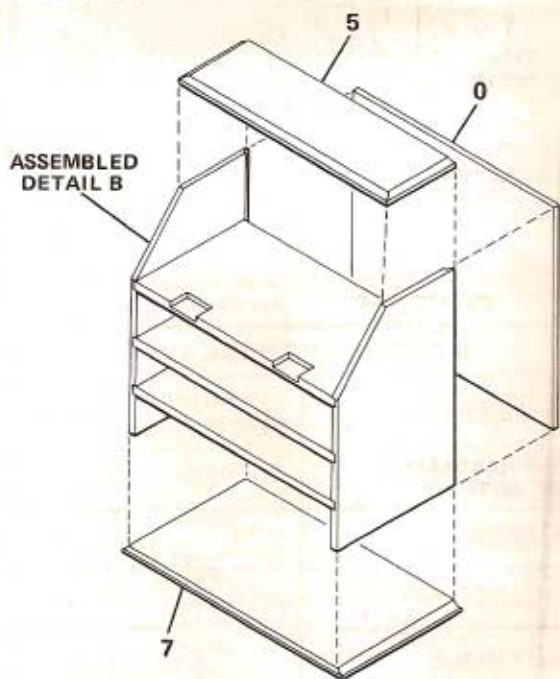

DETAIL C

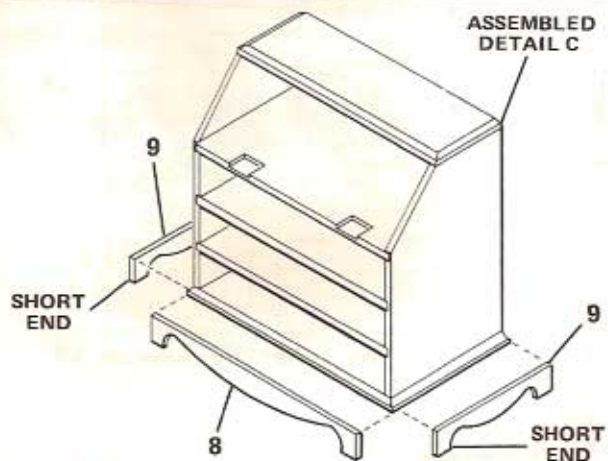

DETAIL D

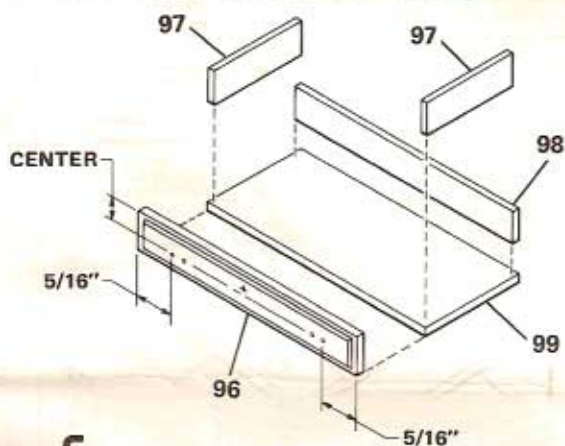

DETAIL E

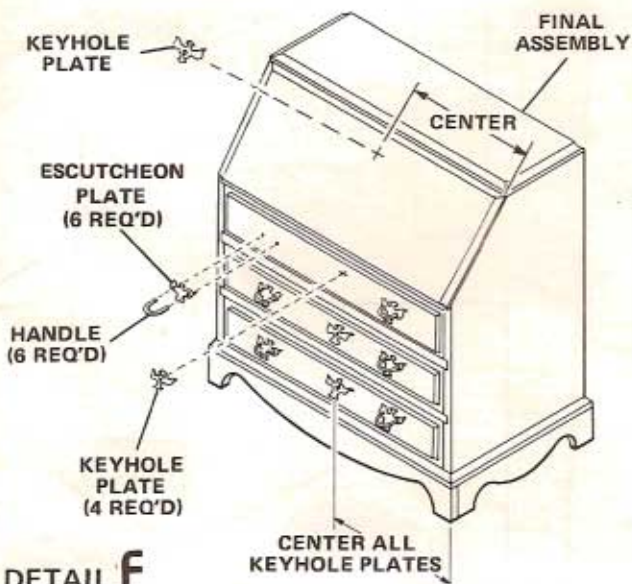
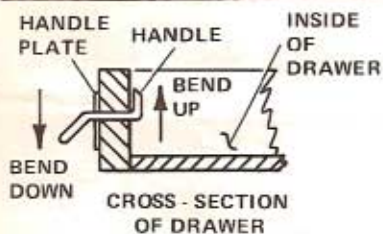

DETAIL F

ASSEMBLY

A. Before starting to assemble your kit, study all illustrations and instructions carefully. Be certain you understand each step before proceeding to the next one.

B. Follow the sequence of steps in the order they are presented. **Do not** skip steps or take any short cuts.

C. Refer to **ALIGNMENT** (page 5) for pattern to be used to align the frame for gluing. When gluing parts together, use a flat toothpick or similar tool to apply a small amount of glue to the parts to be joined. Remove any excess glue promptly with a damp cloth. **Remember to let each glued assembly dry thoroughly before adding the next part.**

D. The Professional Finishing Kit, X-ACTO No. 43801, will produce the authentic mahogany finish of this period and contains a **matching tinted glue**, which is recommended for assembly of this kit. The **tinted glue** is of furniture grade quality, equivalent to that used by professional cabinet makers and its use will avoid the appearance of a glue line at each joint.

E. Prepare the **top shelf** and **tilt top** for hinges (see **DETAIL A**, page 3) as follows:

1. Position the top shelf (part no. 1) and tilt top (part no. 6) edge-to-edge, as shown. Because the tilt top is slightly larger than the top shelf, make sure that the top shelf is centered on the tilt top.

2. Place the two hinges in position on both parts, 1/2 inch in from the side edges of the top shelf (part no. 1). Make sure that each hinge pin is centered over the butted edges of the two parts. Then trace the outline of each hinge on both parts. Use the dimensions shown in **DETAIL A** as a guide.

3. Cut two 1/32-inch deep hinge slots in the top shelf (part no. 1) and in the tilt top (part no. 6). Use an X-ACTO no. 1 knife with a no. 11 blade, or a small chisel.

4. Fit the hinges into the slots and make whatever adjustments are required for a proper fit.

5. In a later step, the hinges will be installed with the small screws. To prepare the screws properly, snip or file off the tips so that approximately 3/32-inch of the threaded portion remains. The purpose of this is to avoid having the tip of the screw protrude through the opposite surface when installed. Holding the screw against the hinge, in one of the slots, will allow you to determine the proper length.

6. With the two parts again in position, and the hinges placed in the slots, mark the location of the hinge screw holes. At each location, make a **very** shallow hole with a no. 65 drill bit. Avoid drilling through the material. As an alternate method, a **blunt** straight pin can be used to make each hole.

7. With the hinges in place, start the screws into the holes and very carefully tighten each screw until it is snug. **Do not overtighten.** Then loosen all screws, remove hinges, and continue with assembly instructions.

F. Begin assembly of the frame (see **DETAIL B**, page 3) as follows:

1. Glue three shelves (part no. 1) into grooves in sides (part no.'s 3 and 4). Align the frame face down on the alignment pattern (see **ALIGNMENT**, page 5).

2. Press the back piece (part no. 0) into place, but **do not** glue. This will help to align the frame and keep the parts in position.

3. Use clamps, or several rubber bands, to hold parts in place until the glue sets sufficiently to continue assembly. (Follow instructions for the glue being used for the proper setting time.)

G. Complete assembly of the frame (see **DETAIL C**, page 3) as follows:

1. Glue the back (part no. 0), top (part no. 5) and bottom (part no. 7) to assembled Detail A. Make sure that the rear edges of the top and bottom are flush with the rear edges of the back and sides and are centered.

2. Secure the parts in position with clamps or rubber bands and put the assembly aside until the glue has set.

H. Continue assembly (see **DETAIL D**, page 3) by gluing two side base supports (part no. 9) and front base support (part no. 8) to the bottom of base, as shown.

I. Assemble the **drawers** (see **DETAIL E**, page 3) as follows:

1. Position a handle plate at the locations shown on the drawer front (part no. 96) and mark the positions of the holes with a straight pin or artist's push pin.

2. Using the straight pin or an artist's push pin, make through-holes at the marked positions.

3. Repeat this procedure for the other drawer front.

4. Glue the two sides (parts no. 97) and back (part no. 98) to the bottom (part no. 99). Then glue the front (part no. 96) to the front edges of the sides and bottom, as shown.

5. Repeat the procedure for the two remaining drawers.

J. You have now completed assembly of the major components of your desk, with the exception of installing brass hardware, which completes the assembly. Proceed first to **FINAL FINISHING**, then to paragraph K, which follows, to complete your assembly.

NOTE: For authenticity, when finishing drawer, finish only the drawer front.

K. Install **brass hardware** (see **DETAIL F**) as follows:

1. Apply a **small** amount of glue to the back of each hinge plate and install hinge in top shelf (part no. 1) and tilt top (part no. 6) using small screws that were previously shortened (see paragraph E, step 5). Repeat the procedure for other hinge. Tighten screws until hinges are snug. **Do not overtighten.**

2. Apply a small amount of glue to the back of a keyhole plate and glue it in position on the tilt top (part no. 6). In the same way, glue keyhole plates to the fronts (part no. 96) of the three drawers.

3. Press a handle through an escutcheon plate. Then apply a **small** amount of glue to the back of the escutcheon plate and install in the previously made holes in one drawer front. (part no. 96). Bend up protruding ends of the handle on the inside of the drawer back to secure it in the holes and bend down front of handles. Repeat this procedure for the five additional handles and handle plates (see **DETAIL F**).

L. You have now completed assembly of your furniture. The completed piece should look like that shown in **DETAIL F** (page 3). The tilt top should swing freely on its hinges and should be aligned squarely when closed. All drawers should slide freely.

FINAL FINISHING

In order to ensure that your piece is stained and highlighted in the tones of the period in which the original furniture was produced, we recommend that X-ACTO Professional Finishing Kit, No. 43801 be used. The following method is used by professional furniture makers, and, if done properly, will result in museum quality.

A. After assembly is completed and the glue has set, **lightly** sand all joint areas to remove excess glue, using 220 grit sandpaper or finer. Moisten a cloth slightly and rub the dampened cloth over the entire wood surface to raise the grain. When all signs of moisture have gone from the wood, resand using a 320 to 400 grit sandpaper.

B. With a small brush, apply a light sealer coat to all edges and end grains. Use the side of the brush rather than the tip, in a wiping motion, so that the sealer does not touch other surfaces. Sealing the edge and end grains will prevent the subsequent stains from penetrating these areas as deeply, resulting in a more uniform stain on all parts.

NOTE: If the X-ACTO Finishing Kit (which contains a high quality sealer) is not used, thinned varnish or lacquer can be used for this purpose.

C. To match the color of furniture of this period apply **X-ACTO Base Stain** or mahogany or cherry stain of your choice with a brush or cloth over the entire wood surface. Immediately wipe off all excess stain leaving an even color on the surface. Allow to dry.

D. Apply a thin coat of **X-ACTO Sealer** or any commercial wood sealer over the base stain. This can be applied with either a brush or with the **X-ACTO Power Sprayer**. Make sure there are no drip marks present. Allow the sealer to dry for at least 6 hours.

X-ACTO POWER SPRAYER No. 43561 can be used to apply sealer, top coat, and paints for outstanding results. This spray ensures application of an even coat, especially on intricate and flat surfaces, and it is highly recommended for finishing your furniture.

E. Lightly go over all surfaces with Grade 000 steel wool until they are smooth to the touch.

F. "**Highlighting**" is a technique of creating light and dark areas and is accomplished by applying the **X-ACTO Glaze Stain** or any commercial glaze stain of your choice (Van Dyck Brown is the color recommended) and then toning by rubbing off the glaze in certain areas, exposing the base stain. In order to "highlight", apply a dark glaze with a brush or rag over the entire piece of furniture. As soon as you have applied this glaze, wipe off the excess. Blend tones of base color and glaze stain by using a piece of soft cloth. There should never be a sharp line of dark color to light color, but rather a smooth blending effect. Lighten the middle surface of the wood, but do not lighten the entire surface. The "**highlighting**" technique will produce museum quality miniature furniture.

G. After the glaze stain has dried for 24 hours, thoroughly and briskly wipe all surfaces with a clean cloth until you are satisfied with the appearance. Apply the **X-ACTO Top Coat** or a coat of lacquer or varnish, with a brush, an airbrush, or with the **X-ACTO Power Sprayer**. Apply two or more top coats with light buffing between coats using Grade 000 steel wool. After each steel wool rubbing make sure all steel wool "dust" is removed thoroughly. (**Continue with ASSEMBLY starting with paragraph K**).

ALIGNMENT

A. Tape this sheet to a smooth, flat surface. Then tape sheet of waxed paper to the pattern so that any excess glue at the joint will not stick to the pattern, making it difficult to remove the completed assembly.

B. Use the alignment pattern shown here to position the indicated parts properly and to hold them in alignment while drying.

alignment pattern

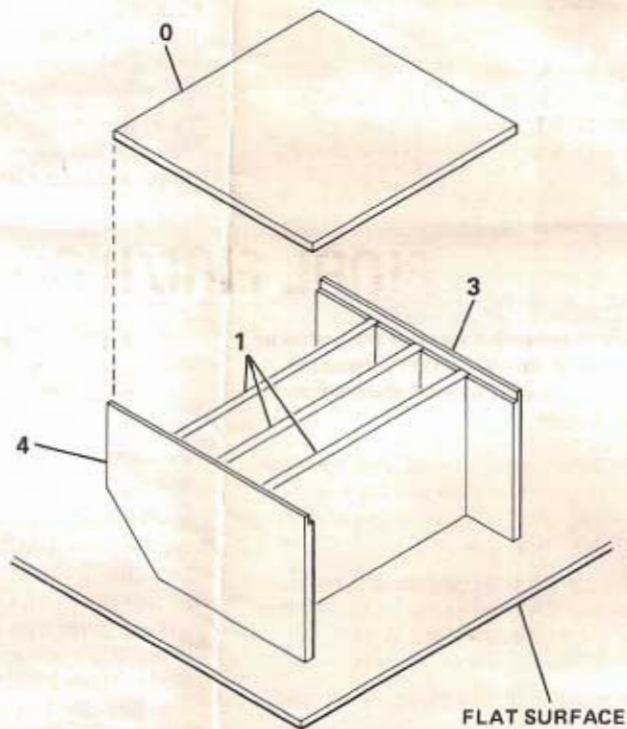
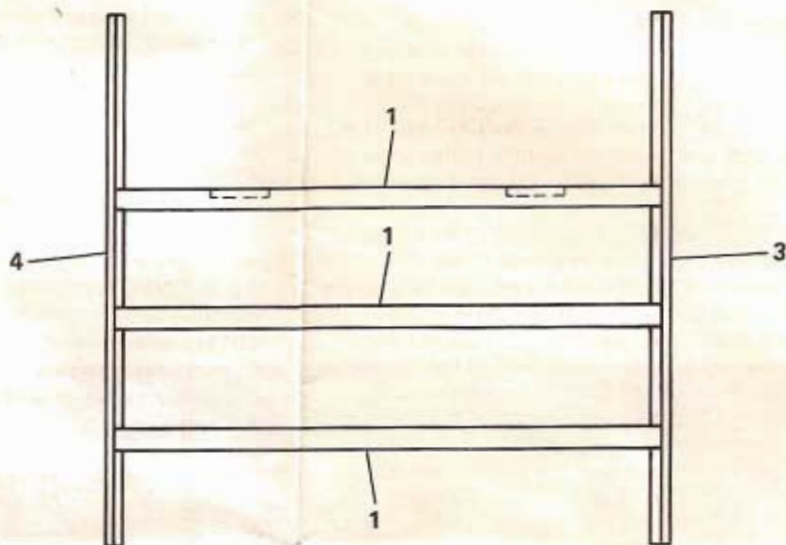

Every effort has been made to insure the completeness of this KIT—however, should any parts be missing, write directly to:
X-ACTO/THE HOUSE OF MINIATURES
45-35 Van Dam Street
Long Island City, N.Y. 11101



When ordering missing parts, please Print your name and address plainly. State the missing PART NO. (See LAYOUT SHEET, page 2), KIT NO. 40017 and the Kit Name, "CHIPPENDALE DESK".