

COLLECTORS NO. 40042



Chippendale
Slant-Front Desk
Circa 1750

American cabinetmakers first began constructing the desk as an individual item of furniture between 1680 and 1690. Initially these desks were two piece affairs with either a flat, or slanted hinged top being placed on a base containing drawers, or cupboard.

After 1700 the one-piece desk became common and one of the most popular versions became the three, or four drawer desk with a slant-front that folded down to provide an additional writing surface.

The interiors were at first left plain, but since the desk quickly became the center of the homes record keeping, the cabinetmaker was soon providing a variety of arrangements of drawers and pigeon holes for his customers.

The treatment of the bases varied. This Chippendale version has a short apron with scrolled bracket feet. Exterior finishes ranged from the traditional warm red mahogany to veneers of exotic, or crotch grained wood.

The addition of a closed top on a desk like this quickly converts it to a tall secretary.

ASSEMBLY AND FINISHING INSTRUCTIONS



AUTHENTIC REPRODUCTIONS IN MINIATURE

The CRAFTMARK® House of Miniature Collectors Series of furniture and accessories have all been carefully researched by specialists through major museum and library collections to assure the highest quality of authenticity in reproduction. Details are extraordinarily accurate to satisfy the most discriminating miniaturist.

All wood parts are machined to assure accurate and precise acceptance of each piece by another.

For a complete catalog of the CRAFTMARK HOUSE OF MINIATURES furniture line and accessories, write to:

THE HOUSE OF
MINIATURES
Customer Service-Catalog Dept.
P.O. Box 468
Delaware, OH 43015-0468

Please include \$2.00 for
Postage & Handling.

INTRODUCTION

BEFORE STARTING

Identify and account for each part by placing it on the Layout Sheet (make sure the correct layout sheet is used when working on multi-kit Instruction Sheets). Should any parts be missing, send a post card to:

THE HOUSE OF MINIATURES
Customer Service - Parts Dept.
P.O. Box 468
Delaware, OH 43015-0468

Please print Name, Address, Part Number (Number from Layout Sheet) and Kit Name and Number on card when ordering.

SANDING

Before assembly, sand all the outer surfaces of individual parts with 220 grit sandpaper, or finer, sanded in the same direction as the wood grain until the surface is smooth. Take care not to round any edges or corners of the pieces. Finish sanding with 280 grit sandpaper.

PRE-ASSEMBLY

A. After sanding, check the proper location and fit of each part by assembling parts loosely, without gluing. Use the **DETAIL VIEWS** as a guide.

B. All parts for CRAFTMARK kits are made on precision milling machines. When adjustments are required, sand to fit.

TOOLS AND MATERIALS

- A. The following tools will be helpful in constructing this kit:
1. Pin Vise
 2. Tweezer
 3. Two-inch Sander
 4. Large Clamp
 5. CRAFTMARK Professional Finishing Kit (or equivalent, see note)
- B. The following materials will be needed to construct this kit:
1. CRAFTMARK Tinted Glue (see note)
 2. Sandpaper-220 and 280 grit
 3. Steel Wool-Grade 0000
 4. White glue (or equivalent)
 5. Small Artist's Brush

NOTE: The CRAFTMARK tinted glue is matched to the finish used in the Professional Finishing Kit. This will produce the authentic finish of the period in which the original Furniture was produced. When not using our glue follow manufacturer's directions.

GLUING

- A. Glue should be applied in small amounts to surface being joined. When gluing dado joints apply glue to dado only.
- B. To ensure a tight fit, squeeze excess glue out of the joints. Hold glued parts together with clamps, rubber bands or weights on the parts.
- C. Wipe off excess glue promptly.
- D. Be sure a glued assembly has dried thoroughly before adding parts.

FINISHING

The CRAFTMARK Professional Finishing Kit enables you to finish your furniture by the same process used by the professional furniture maker. The end result is what is important—there are easier methods, but none that will give the quality results that this process will. If you use a finish other than CRAFTMARK'S refer to the manufacturer's directions.

Detail Views

Kit 40042

Use with steps 1 & 2

Layout Sheet

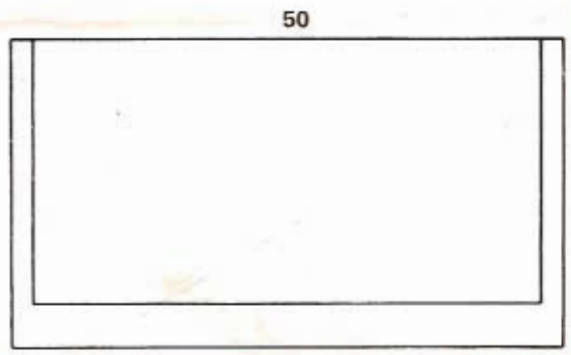
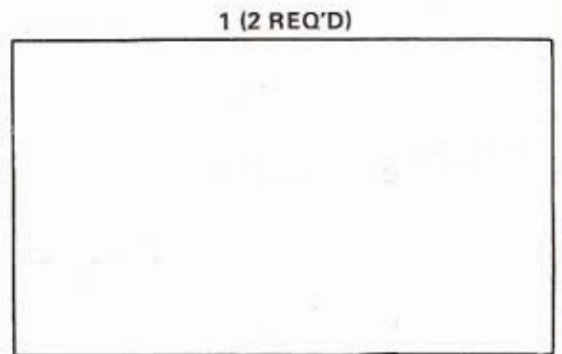
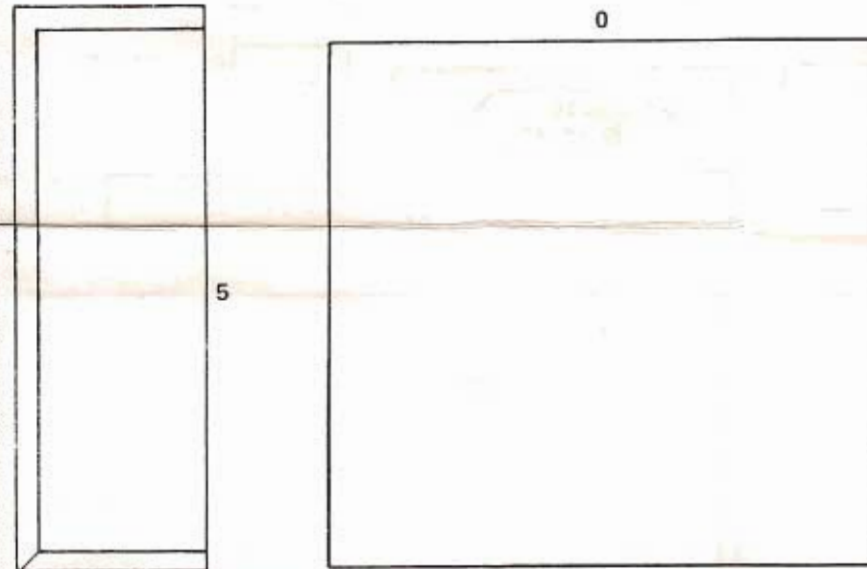
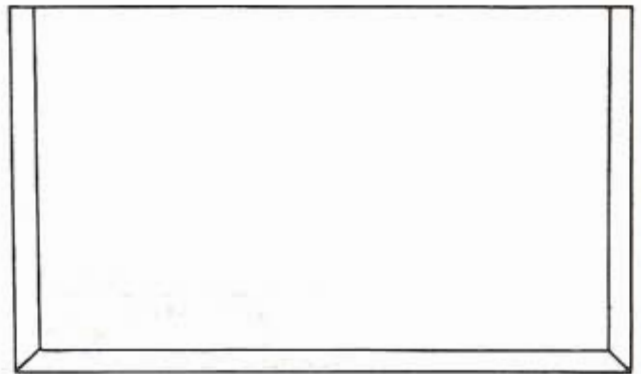
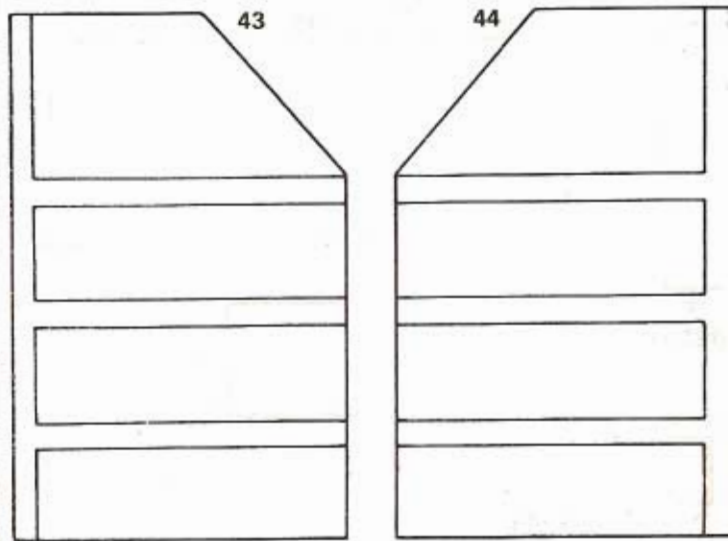

Step 1

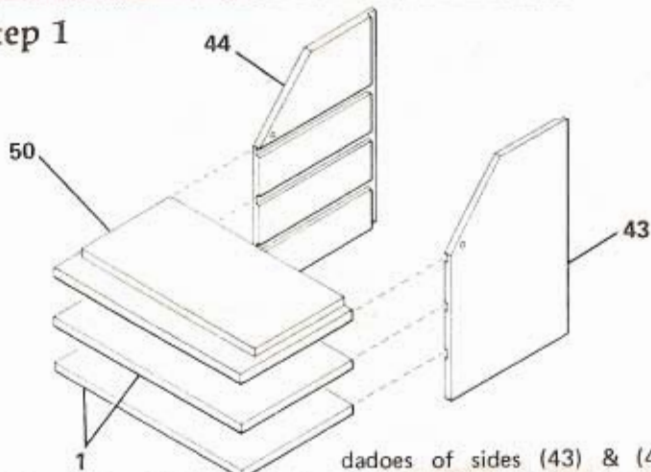

A. Check fit of dividers (1) & (50) into dadoes of sides (43) & (44). Sand to fit if necessary.
B. Glue lower dividers (1) and upper divider (50) into the

dadoes of sides (43) & (44). Dividers should not extend past rabbet on rear edge of sides. If they project slightly in front, sand flush with sides.

C. Square entire assembly.

Step 2

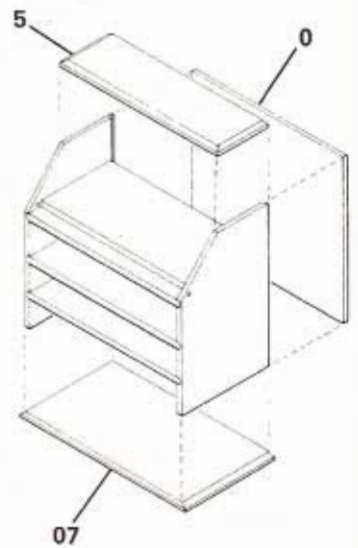

A. Glue back (0) into rabbets on rear edge of the sides.

B. Glue top (5) in place. Cove edges should be at the front and sides. Front edge should be in line with slanted edge of the sides. Sand back edge of top flush with back (0) if necessary.

C. Center and glue entire assembly to base (7) with back edges flush.

Layout Sheet

Kit 40042

Use with steps 3 thru 7

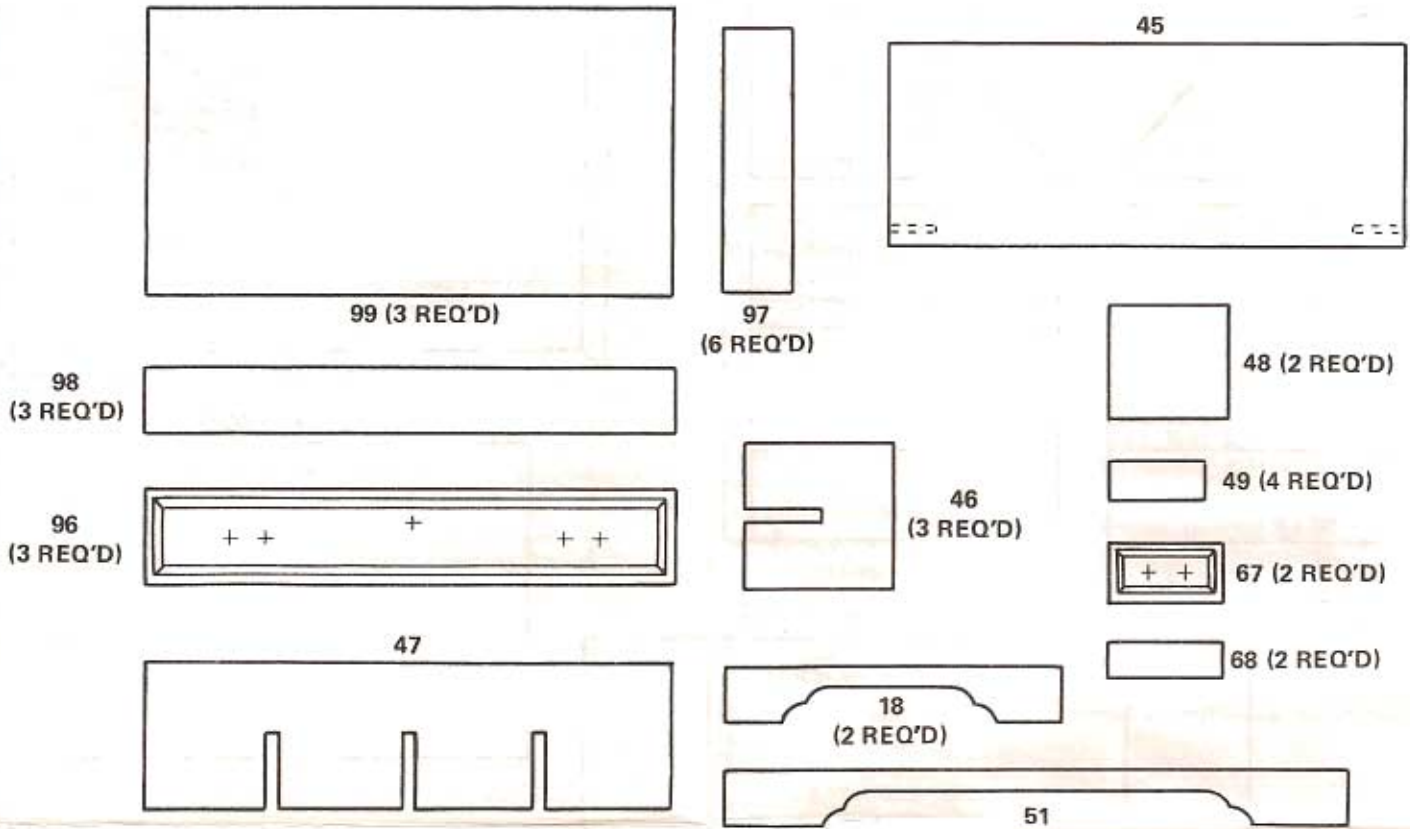

Step 3

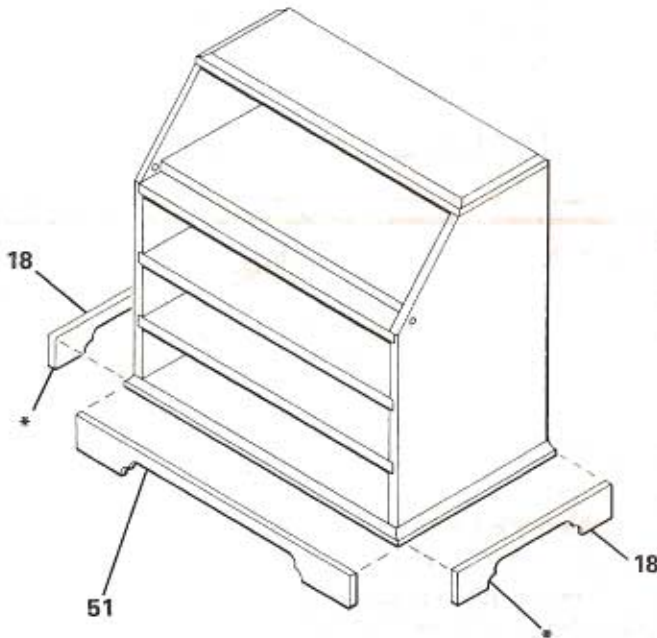

A. Glue front bracket foot frame (51) to the base flush with front edge and ends.

B. Glue side bracket foot frames (18) to the base flush with the edges and to the front

frame. Sand ends flush with back.

NOTE: The feet on the side frames are of different widths. The narrow foot goes forward against the front frame.

Step 4

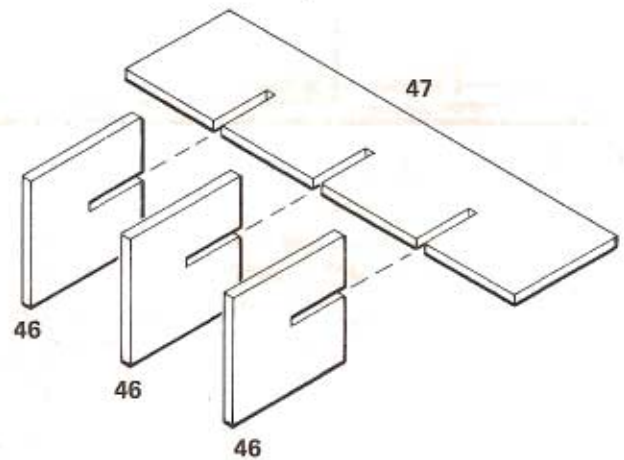

A. Check fit of vertical dividers (46) in slots of horizontal divider (47). Do not force, sand to fit.

B. Glue and square up assembly.

Detail Views





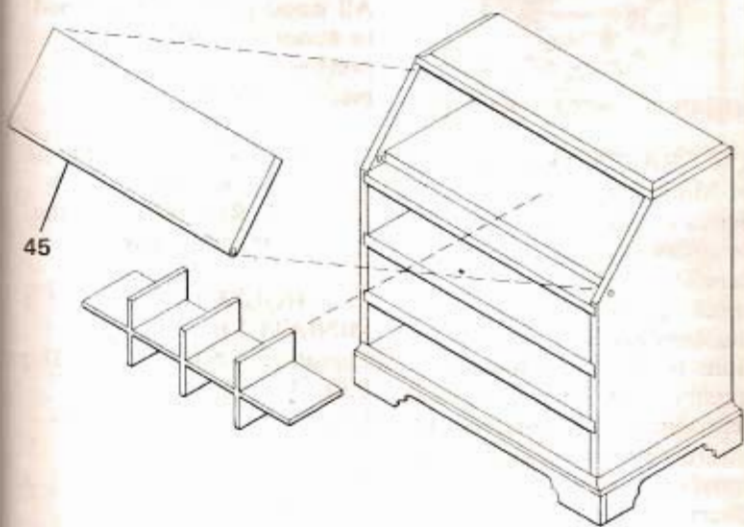

Kit 40042

Step 5



A. Check fit of divider assembly in the desk. It should fit loose enough to allow for finish build up. Do not glue in place until after final finishing.

B. Check fit of hinged front (45). Do not push pins completely in at this point. Remove for finishing.

HARDWARE CHECK LIST		
DESCRIPTION	VISUAL DESCRIPTION	QTY
HANDLE PLATE		8
HANDLE		8
KEYHOLE PLATE		3
ESCUTCHEON		1
KNOB		1
HINGE PIN		2

Step 6

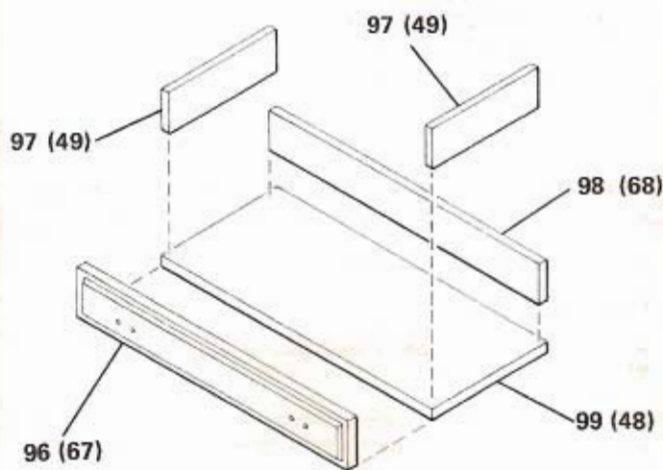

NOTE: Large and small drawers are assembled in the same manner. Numbers in parentheses are the part numbers for the small drawers.

A. Glue sides (97) on top of bottom (99) flush with sides and front edge.

B. Glue back (98) on top of bottom (99) and against sides (97).

C. Glue front (96) to drawer assembly. If interior of drawer is to be left unfinished, apply finish to front (96) prior to gluing in place.

D. Repeat for other two drawers using the appropriate parts.

E. Apply final finish to all parts and assemblies.

Step 7

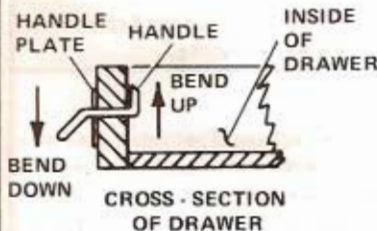
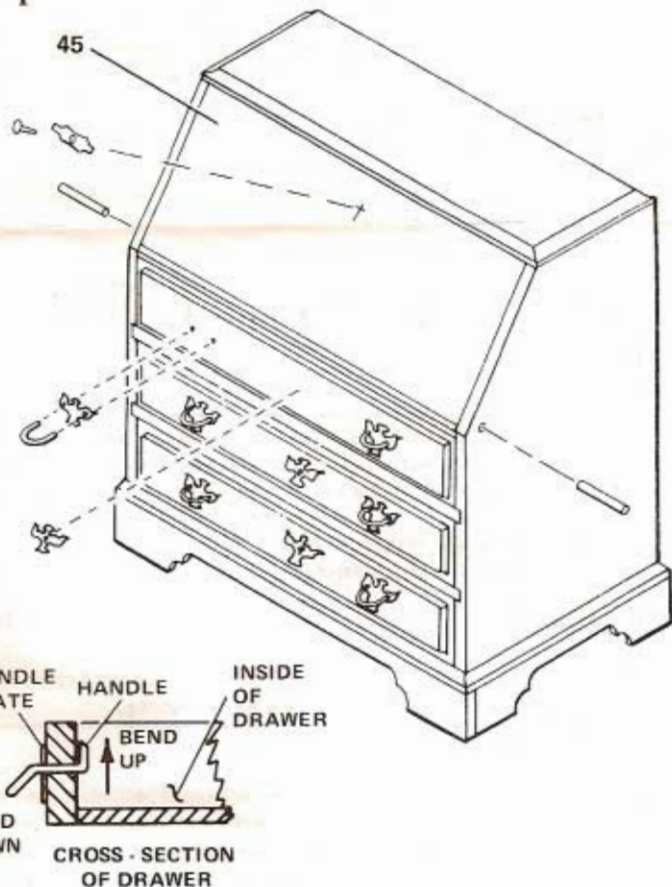

A. Drill holes for all hardware using spacings indicated on appropriate parts on the layout sheet.

B. Place handles through holes in plate, apply a drop of white glue to back of plate and install. Bend front of handle down in front of drawer and the ends up in the interior of the drawer.

Key plates are glued on where indicated.

C. Insert hinge pins through sides and into holes in the ends of the slant front. Check that holes are clear of finish material. If pins are too long, pull out slightly and snip off excess. They should be flush with sides.

D. Install divider assembly.