

COLLECTORS NO. 40044



Lyre-Back Chair

Circa 1800

This chair is typical of the graceful designs of the New York cabinetmaker, Duncan Phyfe in the early part of the 1800's. The design of this chair was his interpretation of the Directoire made during that period when the American taste was being influenced by French designs.

The strings of the lyre shaped splat were often thin brass rods and the frame of the lyre was decorated with a carved acanthus-leaf design. The front of the back supports, side rails, and front legs were sometimes carved with a continuous fluting from top to bottom. Some versions had the front legs terminating in foot shaped like an animals paw.

The shape of the incurved saber legs was borrowed from the Greek "klismos" shape and was used extensively by Phyfe and other cabinetmakers as furniture designs took form to give us the Empire Period in America.

Mahogany was the principal wood used by Phyfe for this chair. Despite the fragile appearance of this design, the sturdiness of its construction have allowed many examples of this piece to survive.

ASSEMBLY AND FINISHING INSTRUCTIONS



AUTHENTIC REPRODUCTIONS IN MINIATURE

The X-ACTO® House of Miniatures Collectors Series® of furniture and accessories have all been carefully researched by specialists through major museum and library collections to assure the highest quality of authenticity in reproduction. Details are extraordinarily accurate to satisfy the most discriminating miniaturist.

All wood parts are machined to assure accurate and precise acceptance of each piece by another.

For a complete catalog of the X-ACTO® HOUSE OF MINIATURES furniture line and accessories, write to:

THE HOUSE OF MINIATURES
Customer Service - Catalog Dept.
80 Newbridge Road
Bergenfield, NJ 07621

INTRODUCTION

BEFORE STARTING

Identify and account for each part by placing it on the Layout Sheet (make sure the correct layout sheet is used when working on multi-kit Instruction Sheets). Should any parts be missing, send a post card to:

THE HOUSE OF MINIATURES
Customer Service - Parts Dept.
2000 Craftmark Center
Statesville, NC 28677-2000

Please print Name, Address, Part Number (Number from Layout Sheet) and Kit Name and Number on card when ordering.

SANDING

Before assembly, sand all the outer surfaces of individual parts with 220 grit sandpaper, or finer, sanded in the same direction as the wood grain until the surface is smooth. Take care not to round any edges or corners of the pieces. Finish sanding with 280 grit sandpaper.

PRE-ASSEMBLY

A. After sanding, check the proper location and fit of each part by assembling parts loosely, without gluing. Use the **DETAIL VIEWS** as a guide.

B. All parts for X-ACTO kits are made on precision milling machines. When adjustments are required, sand to fit.

TOOLS AND MATERIALS

A. The following tools will be helpful in constructing this kit:

1. Two-inch Sander, X-ACTO No. 7042
2. Small Clamp, X-ACTO No. 7003
3. X-ACTO Professional Finishing Kit (or equivalent, see note)

B. The following materials will be needed to construct this kit:

1. X-ACTO Tinted Glue (see note)
2. Waxed paper
3. Sandpaper - 220 and 280 grit
4. Steel Wool - Grade 0000
5. White glue (or equivalent)
6. Small Artist's Brush

NOTE: The X-ACTO tinted glue is matched to the finish used in the Professional Finishing Kit. This will produce the authentic finish of the period in which the original Furniture was produced. When not using X-ACTO glue follow manufacturer's directions.

GLUING

A. Glue should be applied in small amounts to surface being joined. When gluing dado joints apply glue to dado only.

B. To ensure a tight fit, squeeze excess glue out of the joints. Hold glued parts together with clamps, rubber bands or weights on the parts.

C. Wipe off excess glue promptly.

D. Be sure a glued assembly has dried thoroughly before adding parts.

FINISHING

The X-ACTO Professional Finishing Kit enables you to finish your furniture by the same process used by the professional furniture maker. The end result is what is important — there are easier methods, but none that will give the quality results that this process will. If you use a finish other than X-ACTO's, refer to the manufacturer's directions.

Detail Views

Kit 40044

Layout Sheet

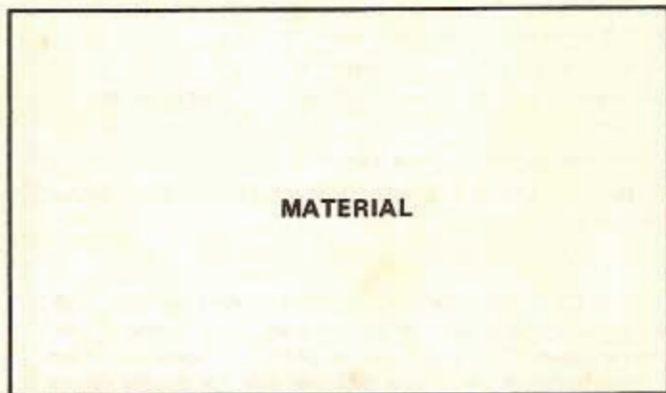
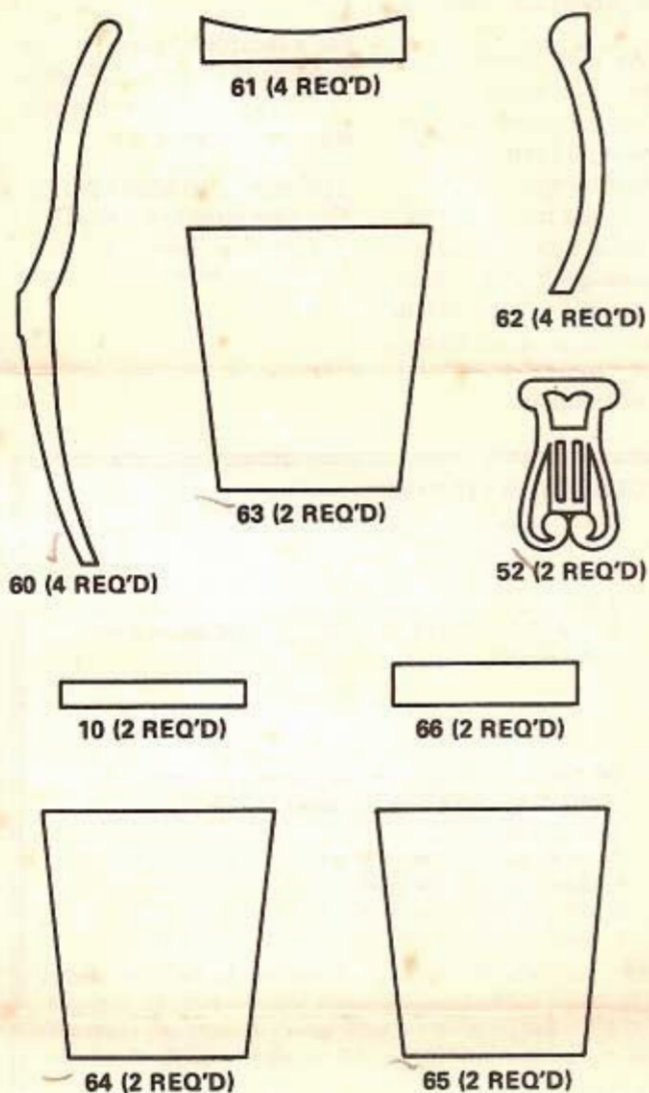

15

Step 1

Alignment

A. Using the Alignment Pattern assemble four sides. After glue has set, slightly round all edges and blend all curves together.

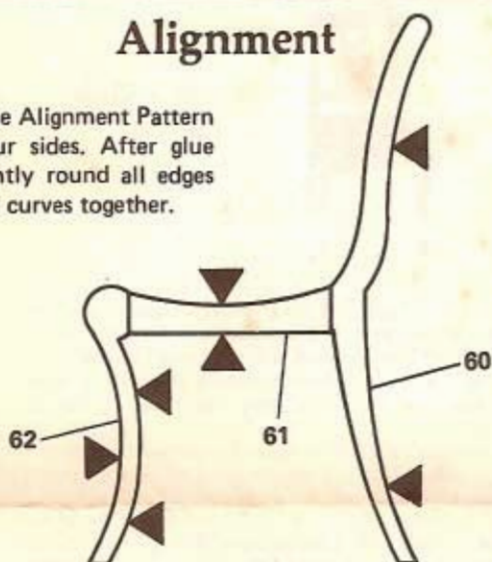

Step 2

A. Glue seat base (63) in place, it should be flush with the bottom of side rails (61) and with the back edge of the rear legs (60).

B. Glue top rail (66) in place, then the splat (52), and then the bottom rail (10).



C. Round top edges of top rail and ends of back supports.

D. Repeat for second chair.

Step 3

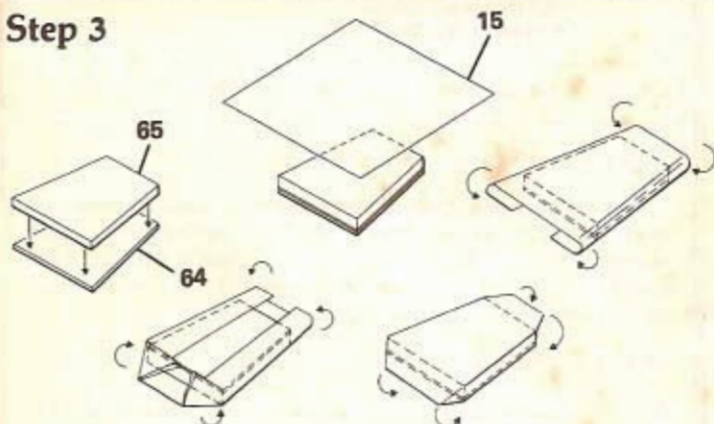

A. With white glue, glue foam cushion (65) to cushion base (64).

B. Cover cushion with material (15) or material of your choice

using white glue to secure material.

C. After final finishing of your chair, glue cushion in place.