

COLLECTORS NO. 40047

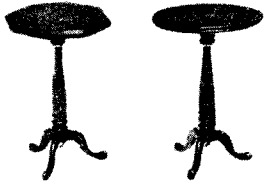

Hepplewhite
Candlestands

Circa 1760

Candlestands and small tables were in great demand by the Colonial households both for their utilitarian value and their decorative value. Hepplewhite styles and designs were similar to those of previous period except for typical Hepplewhite touches such as heavy uses of inlay and occasional special treatment of the tripod legs.

The cyma curved legs were usually terminated in pad or snake feet and the top surfaces were often fluted. Inlay varied from exotic to native burl wood.

The main body of these stands were usually made of the ever popular mahogany, but many that were made by American cabinetmakers were of native woods such as maple and walnut. Since these were used in so many sections of the house and were used in such numbers they relied on form rather than decorations to enhance their appearance. Carving, if used at all, was restricted to the pedestal.

The oval and octagon tops on these two tables were two of the more popular shapes used on this type of table.

ASSEMBLY AND FINISHING INSTRUCTIONS



AUTHENTIC REPRODUCTIONS IN MINIATURE

The X-ACTO® House of Miniatures Collectors Series® of furniture and accessories have all been carefully researched by specialists through major museum and library collections to assure the highest quality of authenticity in reproduction. Details are extraordinarily accurate to satisfy the most discriminating miniaturist.

All wood parts are machined to assure accurate and precise acceptance of each piece by another.

For a complete catalog of the X-ACTO® HOUSE OF MINIATURES furniture line and accessories, write to:

X-ACTO® THE HOUSE OF MINIATURES Dept. KIT
45-35 Van Dam Street
Long Island City,
New York 11101

Please include \$2.00 for postage and handling.

INTRODUCTION

BEFORE STARTING

Identify and account for each part by placing it on the Layout Sheet (make sure the correct layout sheet is used when working on multi-kit Instruction Sheets). Should any parts be missing, send a post card to:

X-ACTO/The House of Miniatures
45-35 Van Dam Street
Long Island City, N.Y. 11101

Please print Name, Address, Part Number (Number from Layout Sheet) and Kit Name and Number on card when ordering.

SANDING

Before assembly, sand all the outer surfaces of individual parts with 220 grit sandpaper, or finer, sanded in the same direction as the wood grain until the surface is smooth. Take care not to round any edges or corners of the pieces. Finish sanding with 280 grit sandpaper.

PRE-ASSEMBLY

A. After sanding, check the proper location and fit of each part by assembling parts loosely, without gluing. Use the DETAIL VIEWS as a guide.

B. All parts for X-ACTO kits are made on precision milling machines. When adjustments are required, sand to fit.

TOOLS AND MATERIALS

A. The following tools will be helpful in constructing this kit:

1. Two-inch Sander, X-ACTO No. 7042
2. Small Clamp, X-ACTO No. 7003
3. X-ACTO Professional Finishing Kit (or equivalent, see note)

B. The following materials will be needed to construct this kit:

1. X-ACTO Tinted Glue (see note)
2. Sandpaper -220 and 280 grit
3. Steel Wool - Grade 0000
4. Small Artist's Brush

NOTE: The X-ACTO tinted glue is matched to the finish used in the Professional Finishing Kit. This will produce the authentic finish of the period in which the original Furniture was produced. When not using X-ACTO glue follow manufacturer's directions.

GLUING

A. Glue should be applied in small amounts to surface being joined. When gluing dado joints apply glue to dado only.

B. To ensure a tight fit, squeeze excess glue out of the joints. Hold glued parts together with clamps, rubber bands or weights on the parts.

C. Wipe off excess glue promptly.

D. Be sure a glued assembly has dried thoroughly before adding parts.

FINISHING

The X-ACTO Professional Finishing Kit enables you to finish your furniture by the same process used by the professional furniture maker. The end result is what is important — there are easier methods, but none that will give the quality results that this process will. If you use a finish other than X-ACTO's, refer to the manufacturer's directions.

Detail Views

Kit 40047

Layout Sheet

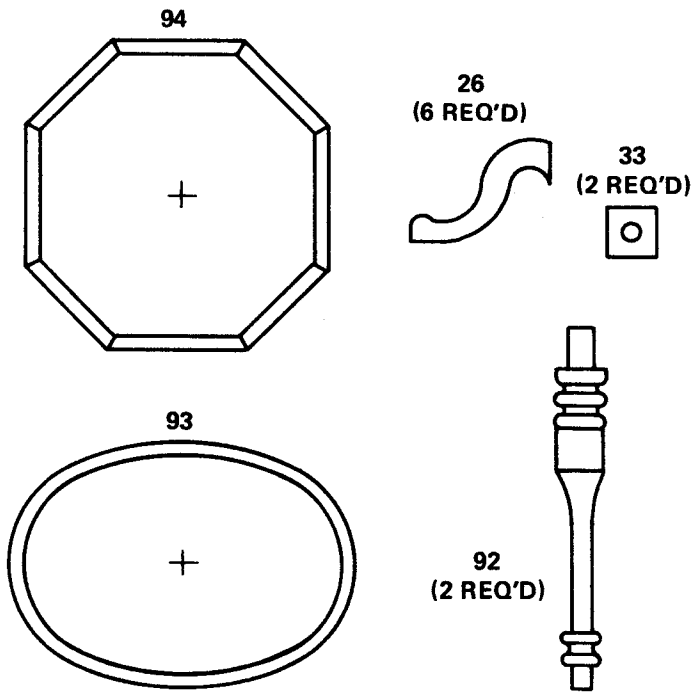

NOTE: Parts included for two candlestands.

Step 1

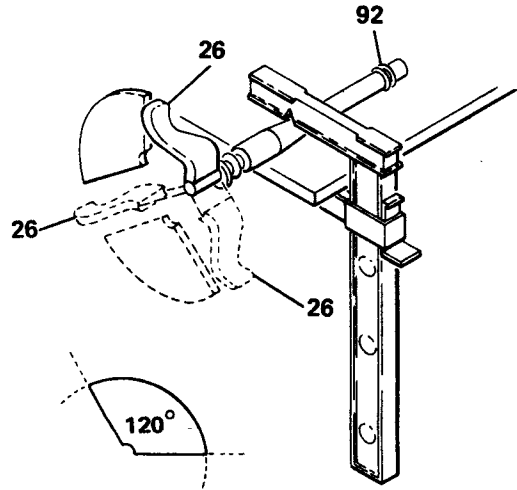

A. Glue on leg (26) to long projection on pedestal. Allow glue to set, then using the 120° guide for proper spacing, glue on other two legs.

B. Repeat for second pedestal.

Step 2

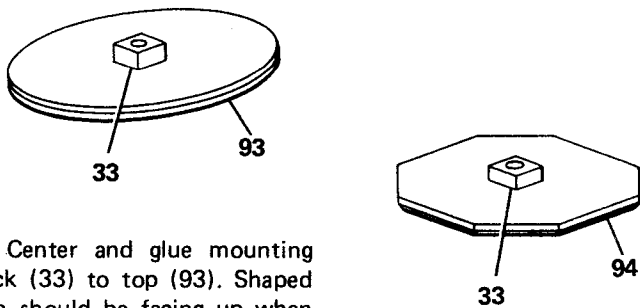

A. Center and glue mounting block (33) to top (93). Shaped edge should be facing up when completed.

B. Center and glue mounting block (33) to top (94). Shaped edge should be facing up when completed.

Step 3

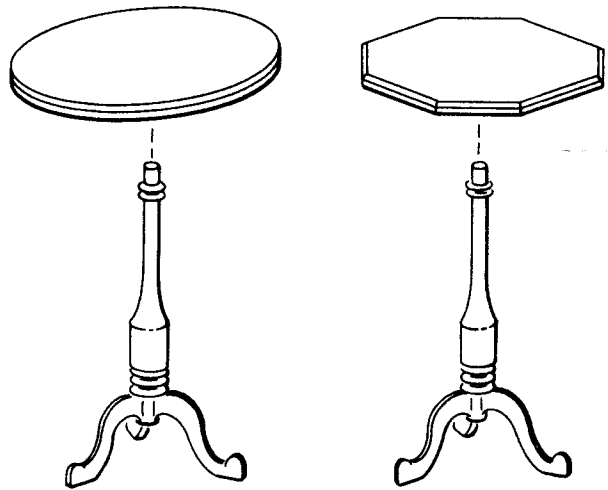

A. Glue tops to pedestals. Check that they are level before glue sets.

B. Apply final finish.