

## COLLECTORS NO. 40072



**Trestle Stand**  
Connecticut:  
Circa 1770-90

The original of this stand had a one-piece pine top with cleated ends and turned maple legs.

Tables such as this one are almost exclusively of New England design. Nowhere else in the world did tables such as this appear in such an abundance and variety. The leg turnings were popular, and each cabinetmaker reflected his artistic interpretation of the cyma scroll design in his work.

Early versions of this type of table could be completely taken apart for ease of storage or shipping. The legs were secured by pegged mortise-and-tenon joints, and the top was held on by pegs or dove-tail tenons.

The table we have adapted is considered a transitional piece since it was built late in the 18th Century; and while it incorporates many of the features and styling of early designs, it was built to be a permanent piece of furniture for everyday use. It also is typical of the more common furniture of that era. Often we tend to think that all the colonial homes were furnished in the elegant styles of Chippendale, Hepplewhite, etc. But, in truth, the majority of the homes were furnished in basic, durable furnishings as typified by this table.

## INTRODUCTION

### BEFORE STARTING

Identify and account for each part by placing it on the Layout Sheet (make sure the correct layout sheet is used when working on multi-kit Instruction Sheets). Should any parts be missing, send a post card to:

**X-ACTO/The House of Miniatures**  
45-35 Van Dam Street  
Long Island City, N.Y. 11101

Please print Name, Address, Part Number (Number from Layout Sheet) and Kit Name and Number on card when ordering.

### SANDING

Before assembly, sand all the outer surfaces of individual parts with 220 grit sandpaper, or finer, sanded in the same direction as the wood grain until the surface is smooth. Take care not to round any edges or corners of the pieces. Finish sanding with 280 grit sandpaper.

### PRE-ASSEMBLY

A. After sanding, check the proper location and fit of each part by assembling parts loosely, without gluing. Use the **DETAIL VIEWS** as a guide.

B. All parts for X-ACTO kits are made on precision milling machines. When adjustments are required, sand to fit.

## ASSEMBLY AND FINISHING INSTRUCTIONS



AUTHENTIC REPRODUCTIONS IN MINIATURE

The X-ACTO® House of Miniature® Collectors Series of furniture and accessories have all been carefully researched by specialists through major museum and library collections to assure the highest quality of authenticity in reproduction. Details are extraordinarily accurate to satisfy the most discriminating miniaturist.

All wood parts are machined to assure accurate and precise acceptance of each piece by another.

For a complete catalog of the X-ACTO® HOUSE OF MINIATURES furniture line and accessories, write to:

X-ACTO® THE HOUSE OF MINIATURES Dept. KIT  
45-35 Van Dam Street  
Long Island City,  
New York 11101

Please include \$2.00 for postage and handling.

### TOOLS AND MATERIALS

A. The following tools will be helpful in constructing this kit:

1. X-ACTO 7003 Small Plastic Clamps
2. X-ACTO #1 Knife
3. X-ACTO Professional Kit (or equivalent, see note)
4. X-ACTO 2042 Sander

B. The following materials will be needed to construct this kit:

1. X-ACTO Tinted Glue (see note)
2. Sandpaper - 220 and 280 grit
3. White glue (or equivalent)
4. Small Artist's Brush

NOTE: The X-ACTO tinted glue is matched to the finish used in the Professional Finishing Kit. This will produce the authentic finish of the period in which the original Furniture was produced. When not using X-ACTO glue follow manufacturer's directions.

### GLUING

A. Glue should be applied in small amounts to surface being joined. When gluing dado joints apply glue to dado only.

B. To ensure a tight fit, squeeze excess glue out of the joints. Hold glued parts together with clamps, rubber bands or weights on the parts.

C. Wipe off excess glue promptly.

D. Be sure a glued assembly has dried thoroughly before adding parts.

### FINISHING

The X-ACTO Professional Finishing Kit enables you to finish your furniture by the same process used by the professional furniture maker. The end result is what is important — there are easier methods, but none that will give the quality results that this process will. If you use a finish other than X-ACTO's, refer to the manufacturer's directions.

# Detail Views

KIT 40072

## Layout Sheet

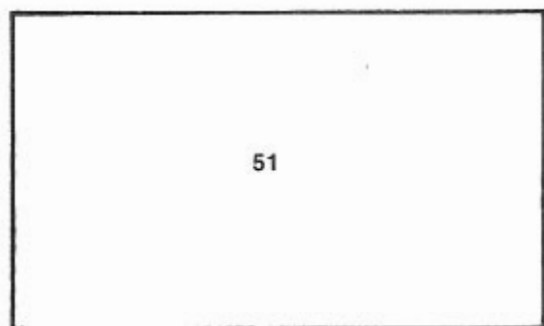

51

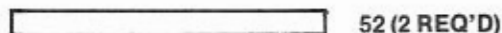

52 (2 REQ'D)



53



54 (2 REQ'D)

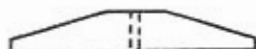

55 (2 REQ'D)



56

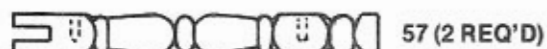

57 (2 REQ'D)



90 (2 Req'd)

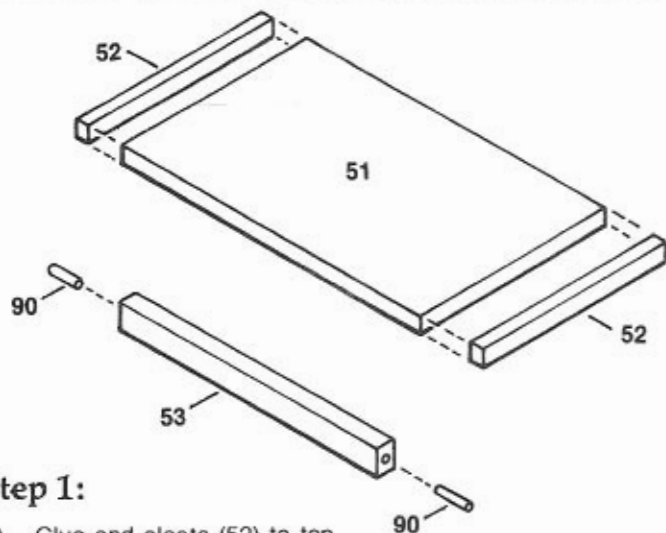

### Step 1:

- Glue end cleats (52) to top (51). Sand assembly smooth.
- Glue sections of dowel (90) into holes in top spreader (53). Cut off so they project out approximately 1/16".

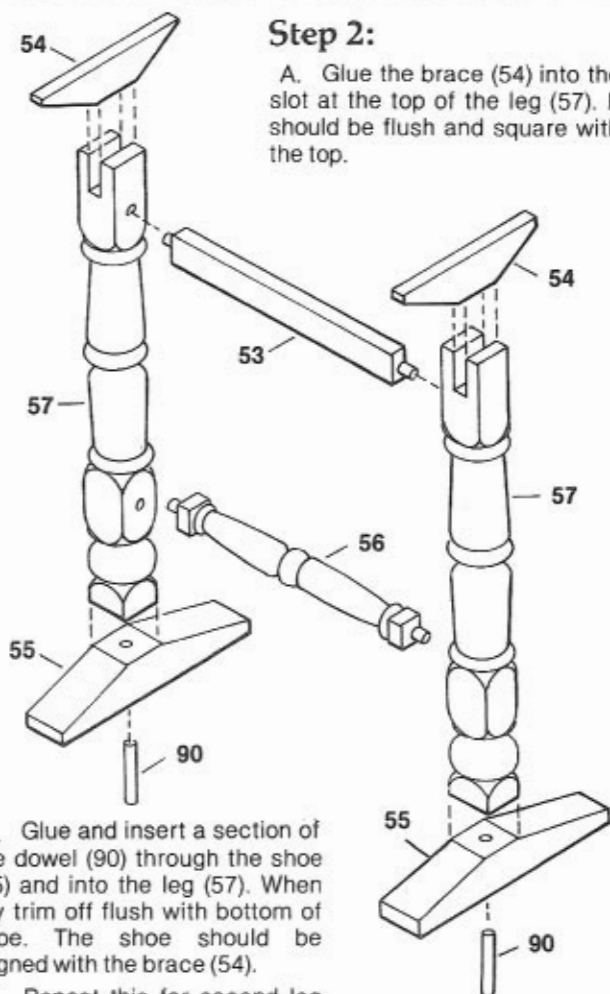

### Step 2:

- Glue the brace (54) into the slot at the top of the leg (57). It should be flush and square with the top.

- Glue and insert a section of the dowel (90) through the shoe (55) and into the leg (57). When dry trim off flush with bottom of shoe. The shoe should be aligned with the brace (54).

- Repeat this for second leg assembly.

- Complete trestle assembly by gluing top spreader (53) and bottom spreader (56) into the appropriate holes in the leg assemblies completed in sections A - C.

### Step 3:

- Place best side of top assembly (made in Step 1) down on work surface. Center trestle assembly braces and make light pencil marks at brace corners as an aid in gluing.

- Glue trestle assembly to the top.
- Apply final finish.

