

ASSEMBLY AND FINISHING INSTRUCTIONS

P/N C7122

COLLECTORS NO. 40022

Chippendale Straight-Top Highboy Circa 1725

The highboy, or tallboy as it was called in England, was very popular during the Queen Anne Period and most of Chippendale's designs for the highboy were merely adaptations of those of the earlier periods.

In the Colonies, makers further adapted Chippendale's designs to fit the needs and tastes of their customers.

The straight-top Highboy that we have reproduced in miniature, is one of those adaptations. The original was made in Philadelphia between 1725 and 1750.

This type of adaptation was in keeping with Chippendale's own philosophy. In his book, "The Gentleman and Cabinet-Makers Director", Chippendale wrote that this book, "as being circulated to assist the one in the Choice, and the other in the Execution of the Designs" which are so contrived that if no one drawing should singly answer the Gentleman's Taste, there will yet be found a Variety of Hints, sufficient to construct a new one".

Chippendale used mahogany almost exclusively in constructing these pieces and the dark lustre of his finishes were complimented by the gleaming brass of the intricately shaped hardware.



COLLECTORS NO. 40023

Chippendale Broken-Bonnet Highboy Circa 1725

The broken-bonnet designation is descriptive of the pediment, or hood capping the main chest. The Highboy, is basically a chest-of-drawers on a frame, or Lowboy.

It came into popularity during the William and Mary period as either a straight or hooded top piece. Late in this period the lines of the hood, or bonnet, were broken

to add variations to the design. During the Queen Anne period, the broken-bonnet style became very popular and Chippendale adapted this styling in his versions of the Highboy.

Chippendale embellished the pediments and finials of his highboys with rich and ornate carvings. The cabriole legs on the Chippendale Highboys were characterized by the ball-and-claw foot and the knees were usually richly carved. Highboys constructed by Chippendale were almost exclusively made of mahogany, but in the Colonies many versions were made of the readily available native woods such as walnut and cherry. Further decorative touches were added by the use of decorative escutcheon plates behind the drawer handles and surrounding the keyholes on almost every drawer.



AUTHENTIC REPRODUCTIONS IN MINIATURE

The X-ACTO® House of Miniatures Collectors Series of furniture and accessories have all been carefully researched by specialists through major museum and library collections to assure the highest quality of authenticity in reproduction. Details are extraordinarily accurate to satisfy the most discriminating miniaturist.

Every item in the line is an authentic reproduction in miniature of regular-size furniture created by master craftsmen during the Colonial period, precision scaled, one inch to one foot.

All wood parts are machined to assure accurate and precise acceptance of each piece by another.

For a complete catalog of the X-ACTO® HOUSE OF MINIATURES furniture line and accessories, write to:

X-ACTO / THE HOUSE OF MINIATURES
Dept. KIT 45-35 Van Dam Street, Long Island City, New York 11101.

Please include \$1.00 for postage and handling.

X-ACTO

© X-ACTO, a unit of CBS, Inc. 1978

www.TheHouseOfMiniatures.org

INTRODUCTION

BEFORE STARTING

Identify and account for each part by placing it on the Layout Sheet (make sure the correct layout sheet is used when working on multi-kit Instruction Sheets). Should any parts be missing, send a post card to:

X-ACTO/The House of Miniatures
45-35 Van Dam Street
Long Island City, N.Y. 11101

Please print Name, Address, Part Number (Number from Layout Sheet) and Kit Name and Number on card when ordering.

SANDING

NOTE: When using sandpaper, remember that the higher the grit number, the finer the finish.

A. One sanding method that has proved successful is the use of a sanding platform. Tape a sheet of sandpaper of the proper grit size to a hard flat surface such as a table top or wood block. Press down lightly and move the piece to be sanded in the same direction as the wood grain until the surface is smooth. Take care not to round any edges or corners of the pieces.

B. Before assembly, sand all the outer surfaces of individual parts with 220 grit sandpaper, or finer. Finish sanding with 280 grit sandpaper or finer.

PRE-ASSEMBLY

A. After sanding, check the proper location and fit of each part by assembling parts loosely, without gluing. Use the **DETAIL VIEWS** as a guide.

B. All parts for X-ACTO kits are made on precision milling machines. When adjustments are required, sand to fit.

TOOLS AND MATERIALS

A. The following tools will be helpful in constructing this kit:

1. Knife, X-ACTO No. 1, with Blade, X-ACTO No. 11
2. Tweezer, X-ACTO No. 36
3. Two-inch Sander, X-ACTO No. 42
4. Large Clamp, X-ACTO No. 4004
5. Small Clamp, X-ACTO No. 4003
6. X-ACTO Professional Finishing Kit (or equivalent, see note)

B. The following materials will be needed to construct this kit:

1. X-ACTO Tinted Glue (see note)
2. Waxed paper
3. Sandpaper - 220 and 400 grit
4. Steel Wool - Grade 0000
5. White glue (or equivalent)
6. Small Artist's Brush

NOTE: The X-ACTO tinted glue is matched to the finish used in the Professional Finishing kit. This will produce the authentic finish of the period in which the original Furniture was produced. When not using X-Acto finishing kit follow Mfg Specs.

GLUING

A. Glue should be applied in small amounts to surface being joined. When gluing dado joints apply glue to dado only. On end cuts, it may be necessary to apply a second coat of glue before joining the parts.

B. To ensure a tight fit, squeeze excess glue out of the joints. Hold glued parts together with clamps, rubber bands or weights on the parts.

C. Wipe off excess glue promptly.

D. Be sure a glued assembly has dried thoroughly before adding parts.

Final Finishing for X-ACTO Professional Finishing Kit

The following process is the same method professional furniture makers use. The end result is what is important—there are easier

methods, but none that will give quality results that this process will.

NOTE: READ EACH STEP THOROUGHLY BEFORE PROCEEDING

A. Final Sanding. Lightly dry sand with (280) grit, garnet paper or finer, sanding with the grain. Your surface should, when finished, be very smooth.

B. Seal End and Edge Grains. Using the **Clear Finish/Sealer** as a sealer, apply a coat to all end grains with a small brush. Do NOT allow sealer to touch other surfaces.

DO NOT LOAD BRUSH WITH SEALER

Allow Drying Time - 12 Hours or more

C. Base Stain. Using the **BASE STAIN**, which is an oil base stain, apply a coat over the entire wood surface using a brush or cloth. **Immediately Wipe Off** all stain leaving an even color over the entire wood surface. This base color will be seen in the high-lighted area after the glaze stain has been applied.

NOTE: When finishing drawers - stain the face piece of the drawer only. This will add authenticity to your piece as regular-size furniture never has stained drawer interiors.

Allow Drying Time - 12-18 Hours

D. Sealing in Base Stain. In order to seal the base stain from subsequent coats that have the same solvent as the base stain, a sealer coat must be applied. Using the **Clear Finish/Sealer** apply a coat over the entire piece - using a brush or sprayer. Whichever method is used, be sure there are no drop marks. This should merely be a thin coat.

Allow Drying Time - 12 Hours or more

E. Glaze Stain. Apply the **Glaze Stain** with a brush, or rag, to the entire surface of your piece of furniture.

At this point you have a choice of achieving two types of finishes. Wiping the glaze stain off evenly until only a thin layer of color remains will produce an attractive finish with the tone you have selected.

Highlighting is a technique of light and dark areas that is accomplished by **Toning** or **Rubbing off the Glaze Stain** in areas exposing the base stain. With a soft cloth start blending tones of base stain and glaze stain by rubbing off the glaze stain starting from the middle of the piece and working outwards. The middle should be light with darker tones toward the outside edge.

THERE SHOULD NEVER BE A SHARP LINE OF DARK TO LIGHT COLOR - BUT RATHER A SMOOTH BLENDING EFFECT.

NOTE: If you are not satisfied with your first attempt in Highlighting, . . . merely wipe off the Glaze Stain from entire piece.

Allow Drying Time - 24 Hours

F. Final Finish or Top Coat. After the Glaze Stain has dried 24 hours, thoroughly wipe, **BRISKLY, BUT LIGHTLY**, the entire piece with a clean cloth.

Using the **Clear Finish/Sealer** apply an even coat over the entire surface of your piece of furniture with a soft brush, or sprayer.

Allow Drying Time - 12 Hours or more between each coat

Two or more coats of **Clear Finish** should be applied with 12 hours drying time between coats. . . after at least two coats have been applied a smoother finish may be attained by lightly buffing with No. 0000 steel wool. If additional coats of finish are applied, lightly buff between coats with No. 0000 steel wool.

NOTE: After each steel wool rubbing, make sure all steel wool "dust" is thoroughly removed.

(These instructions are for the Mahogany (P/N 43804), Walnut (P/N 43802), and Colonial (P/N 43803) Finishing Kits).

Layout Sheet

KIT 40022 / 40023

(Sheet 2 of 2)

These Parts To Be Used For Steps 7 Thru 10

Fold Over During Assembly

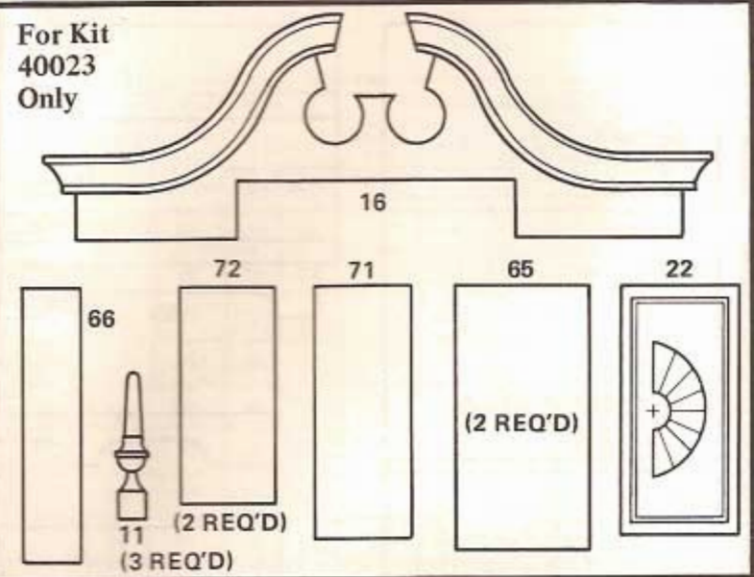
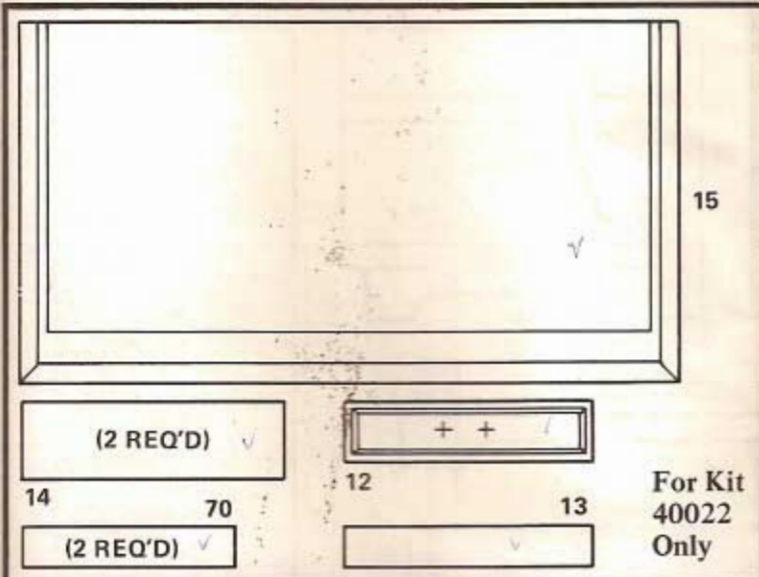

Common Parts For Both Kits 40022 And 40023

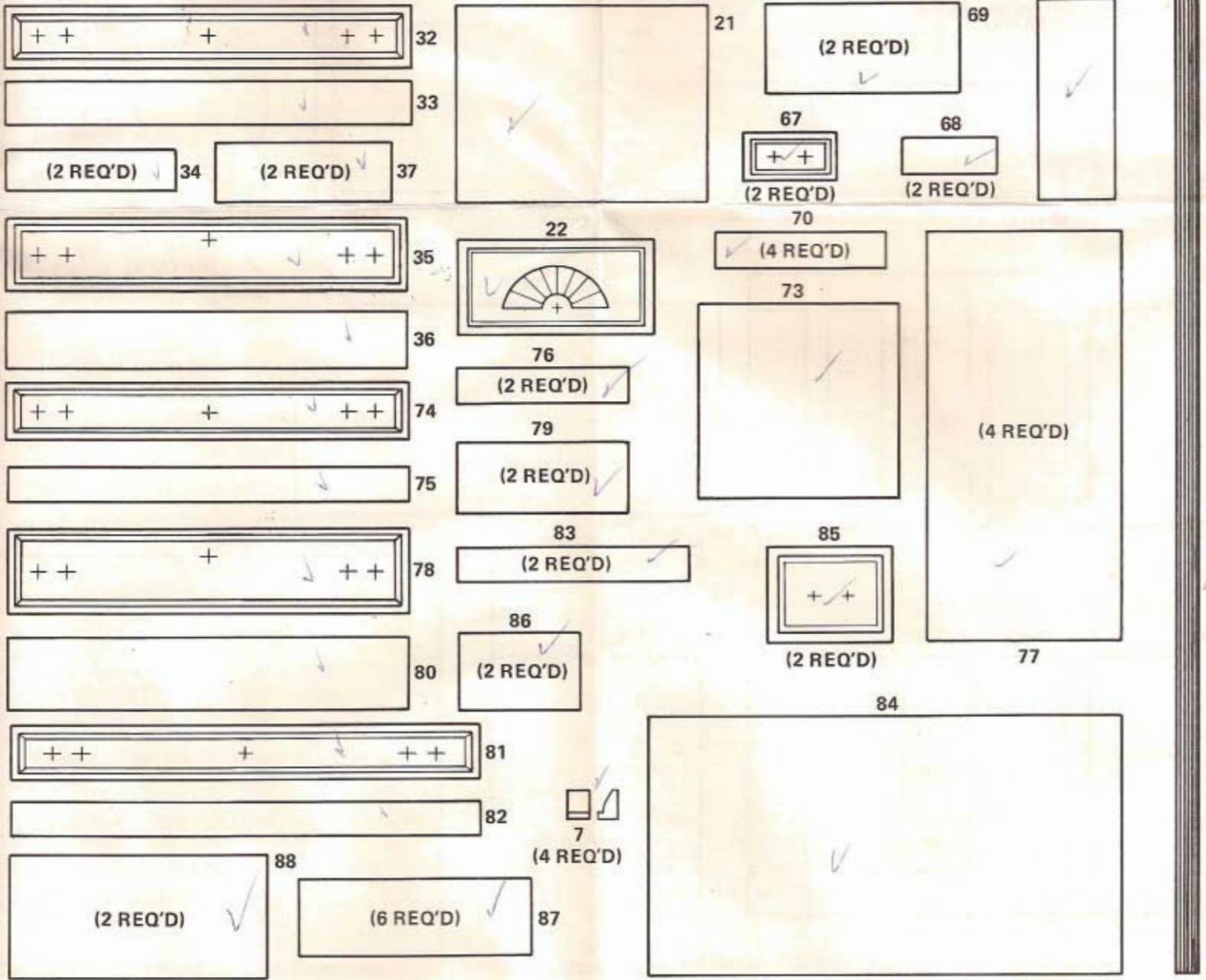

Layout Sheet

KIT 40022/40023

These Parts To Be Used For Steps 1 Thru 6

(Sheet 1 of 2)

Fold Over For Steps 7 Thru 10



57 (2 REQ'D)

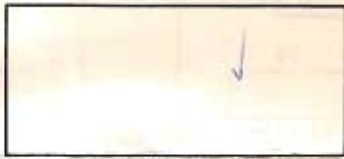

58 (2 REQ'D)

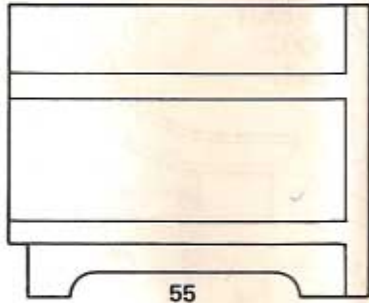

55

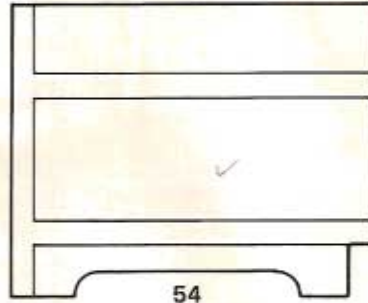

54

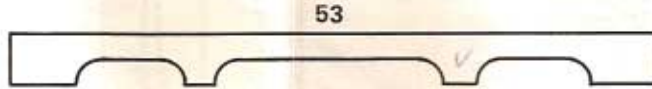

53

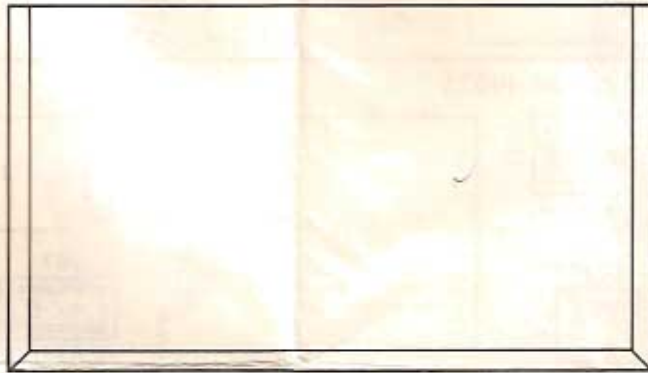

59

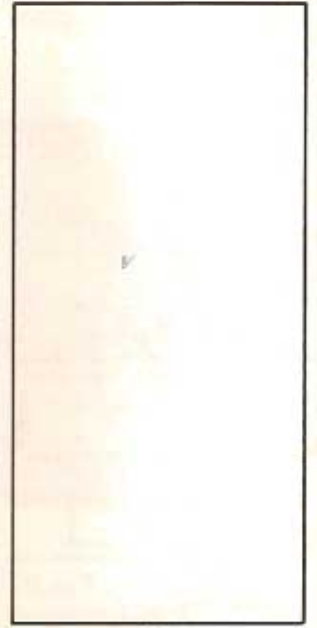

56



24
(4 REQ'D)

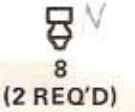

8
(2 REQ'D)

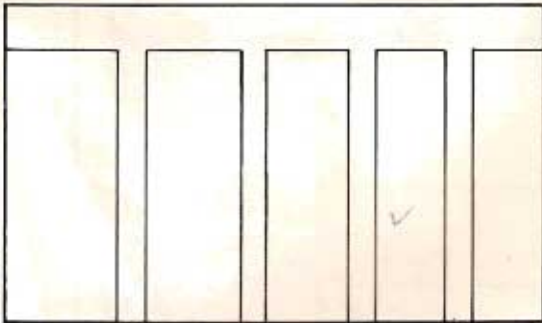

60



63
(3 REQ'D)

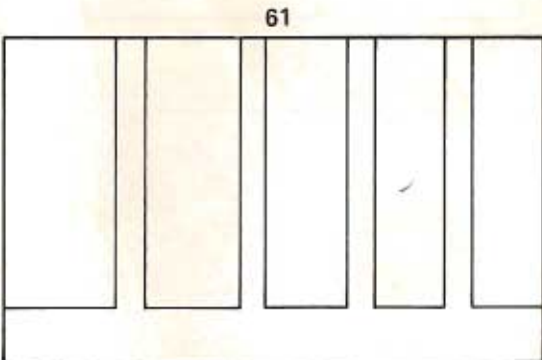

61

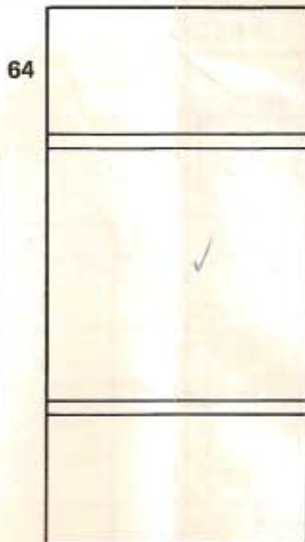

64

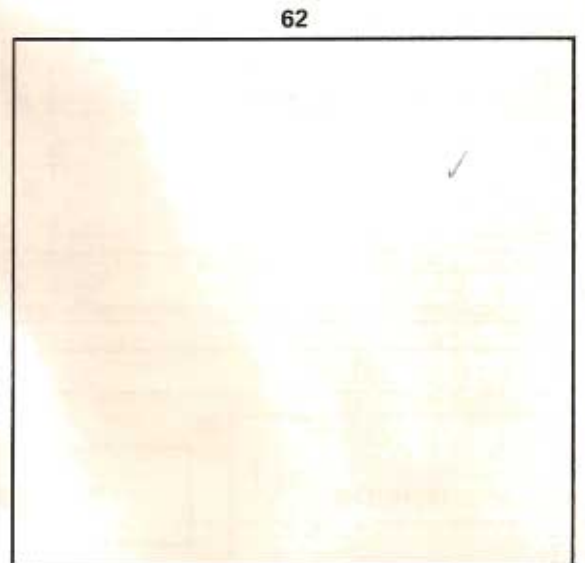

62

Detail Views

KIT 40022 / 40023

(Use Layout Sheet 1 of 2)

Step 1

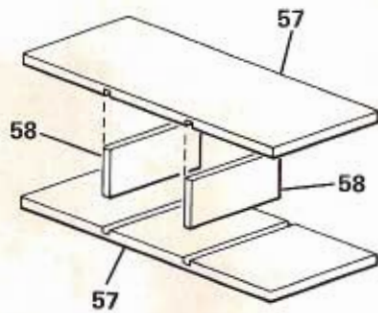

NOTE: Make certain that parts (57 and (58) are flush at front edges.

A. Glue vertical drawer dividers (58) into dadoes in horizontal drawer dividers (57).

Step 4

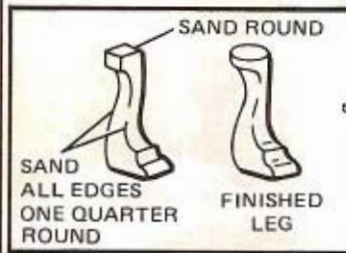

NOTE: Legs may be shaped prior to assembly, by sanding as shown.

A. Center and glue finials (8) to projections on base front (53).

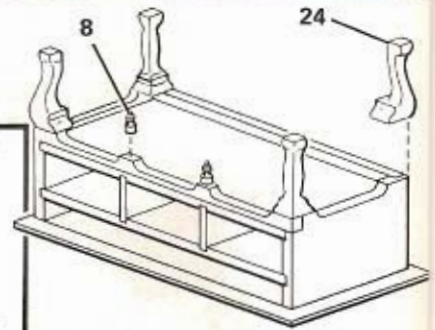

B. Shape legs by sanding.

C. Sand base of leg until it is round.

D. Glue legs (24) to assembly keeping outside edges of legs flush with assembly.

Step 2

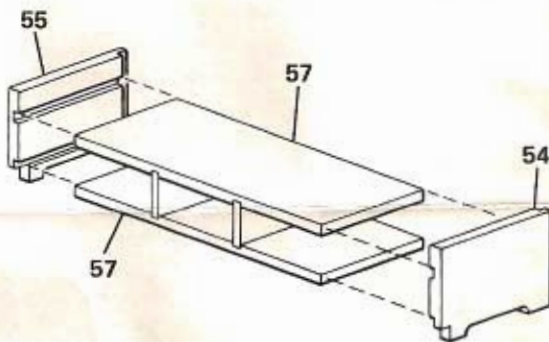

NOTE: Make certain parts (54) and (55) are flush with front edge of horizontal dividers (57).

A. Glue horizontal dividers (57) into dadoes of parts (54) and (55).

Step 5

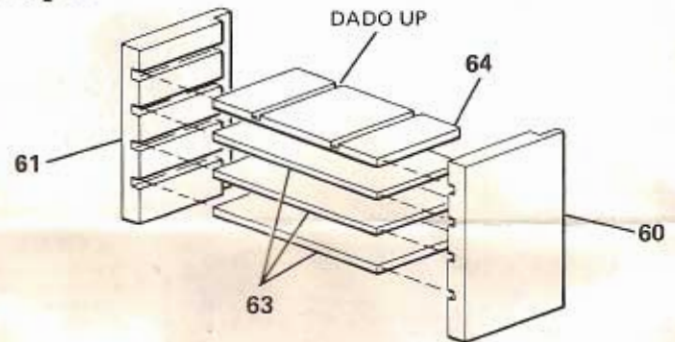

A. Glue horizontal draw dividers (63) and (64) into dadoes of side pieces (60) and (61).

NOTE: Horizontal draw divider (64) must be on top, with dadoes up.

Make certain parts (63) and (64) are flush with front edge of parts (60) and (61).

Step 3

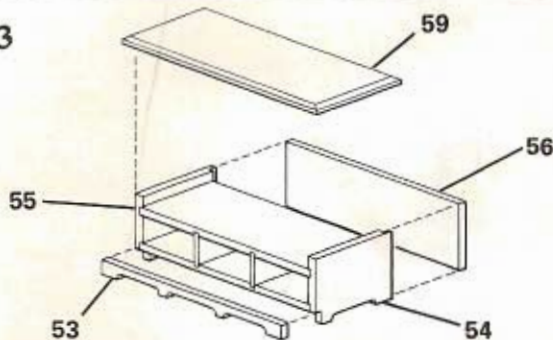

NOTE: Make certain back (56) is flush with top and bottom edges of parts (54) and (55) and all parts are squared.

A. Glue back (56) into rabbets on side pieces (54) and (55). Keep bottom edges flush.

B. Glue top (59) to top edges of parts (54), (55) and (56).

C. Glue base front (53) to notches in parts (54) and (55).

Step 6

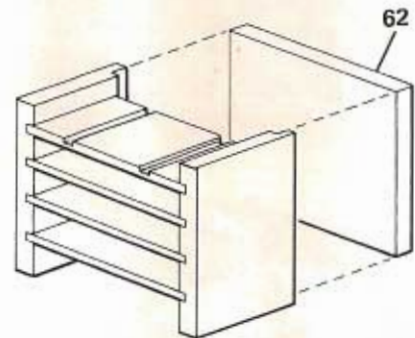

NOTE: Make certain back (62) is flush with top and bottom edges of parts (60) and (61) and all parts are squared.

A. Glue back (62) into rabbets on side pieces (60) and (61).

Detail Views

KIT 40022 / 40023

(Use Layout Sheet 2 of 2)

Step 7a

KIT 40022

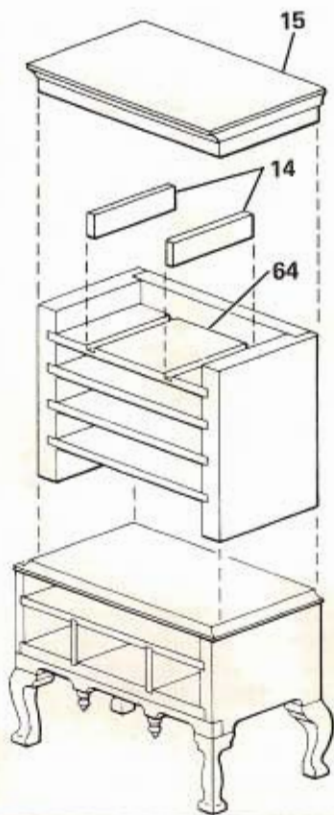

A. Glue vertical dividers (14) into dadoes of part (64). Make certain front edges are flush.

NOTE: Keep all rear edges flush during the following steps.

B. Glue top (15) to upper portion of Chest. Keep back edges flush.

C. Glue base (assembled in step 4) to upper portion of Chest. Center with back edges flush.

Step 7b

KIT 40023

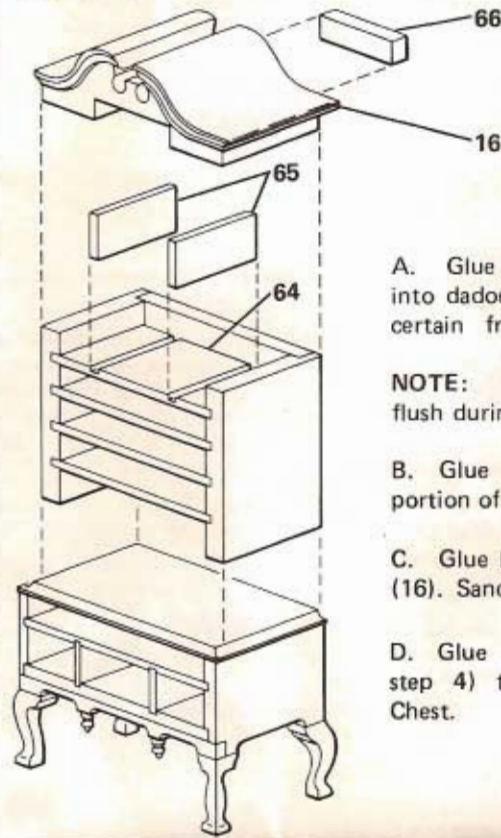

A. Glue vertical dividers (65) into dadoes of part (64). Make certain front edges are flush.

NOTE: Keep all rear edges flush during the following steps.

B. Glue top (16) to upper portion of Chest.

C. Glue back filler (66) to top (16). Sand flush if required.

D. Glue base (assembled in step 4) to upper portion of Chest.

Step 8a

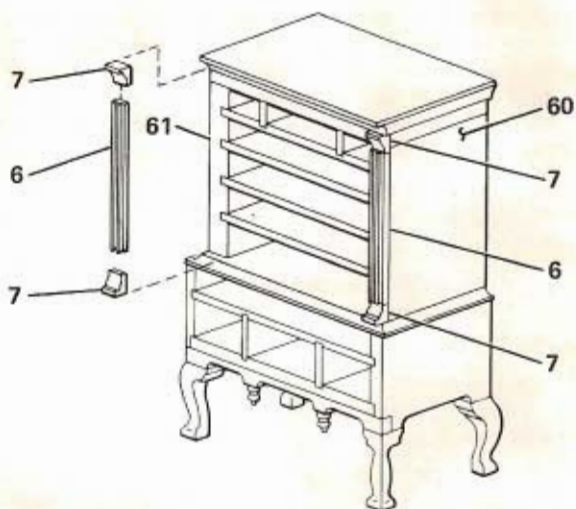

A. Glue column caps (7) to sides (60) and (61). Make certain they are centered.

B. Cut column molding (6) and glue to Chest. Make certain molding is centered.

NOTE: Refer to Final Finishing.

Step 8b

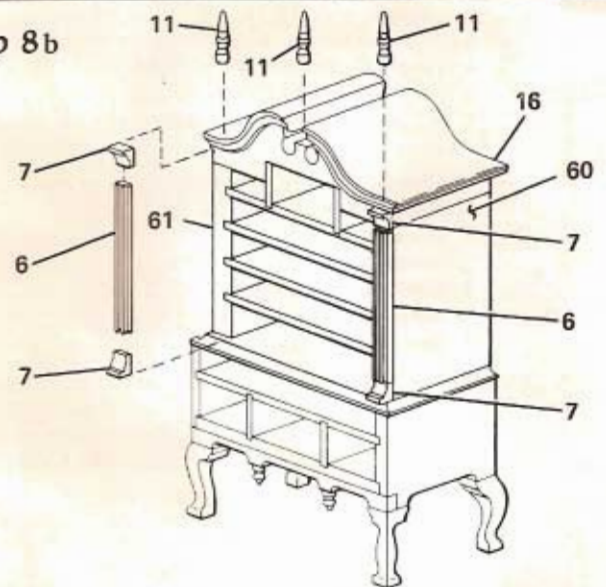

A. Glue column caps (7) to sides (60) and (61). Make certain they are centered.

B. Cut column molding (6) and glue to Chest. Make certain molding is centered.

C. After final finishing, glue finials (11) to top (16).

NOTE: The left and right finials are aligned so that they appear as projections of the columns through the top. The center finial is centered on the projection flush with the front edge.

NOTE: Refer to Final Finishing. When finishing broken bonnet top (16) repeat sanding and sealing steps to front of top.

Detail Views

KIT 40022 / 40023

Drawer Guide

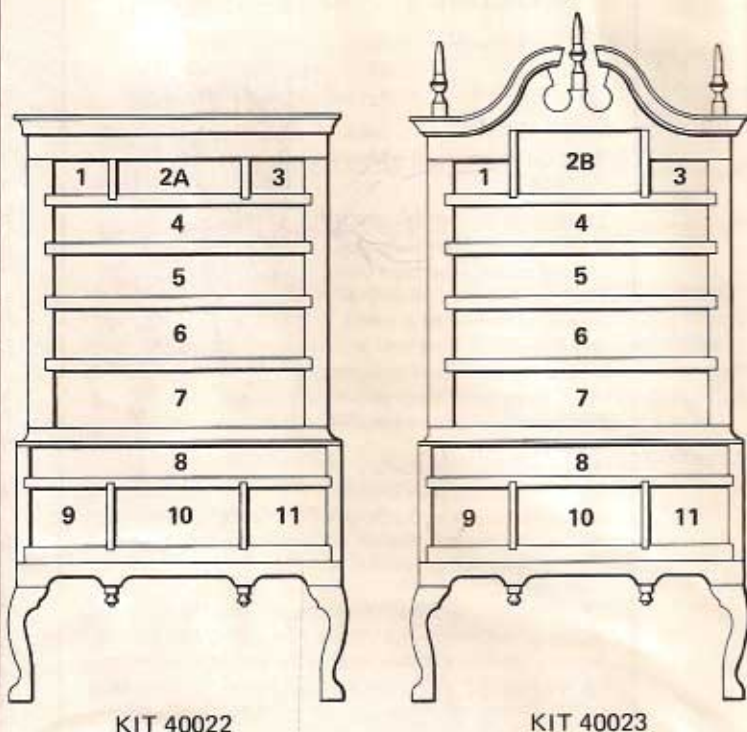

DRAWER ASSEMBLY GUIDE					HARDWARE GUIDE (SEE NOTE)				
DRAWER NO.	FRONT	BOTTOM	SIDES	BACK	ESCUTCHEON	BAIL	KEY PLATE	ROUND ESCUTCHEON	BRAD
1	67	69	70	68	1	1			
2A	12	73	70	13	1	1			
2B	22	73	72	71				1	1
3	67	69	70	68	1	1			
4	74	77	76	75	2	2	1		
5	32	77	34	33	2	2	1		
6	35	77	37	36	2	2	1		
7	78	77	79	80	2	2	1		
8	81	84	83	82	2	2	1		
9	85	88	87	86	1	1			
10	22	21	87	71				1	1
11	85	88	87	86	1	1			

NOTE: TEMPLATES FOR HARDWARE LOCATION ARE FOUND ON LAYOUT SHEET.

Step 9

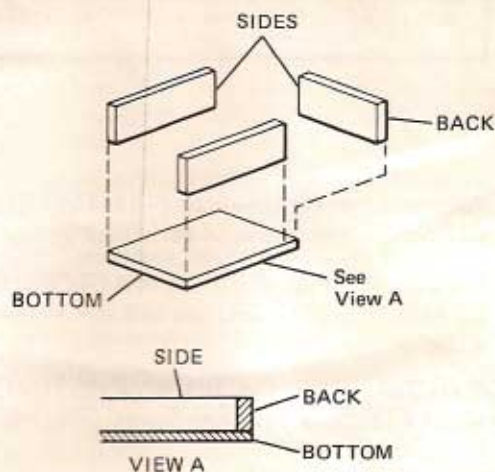

NOTE: The following instructions apply to all drawers. Use the above views and table to find correct parts. Use white glue for assembly of drawers, if inside is not going to be stained.

A. Use layout sheet for location of hardware and mark position of holes with pin.

B. Drill through holes, as marked using a 65 drill bit.

C. Glue sides to bottom making certain they are flush with front edge.

D. Glue back to bottom and against rear edges of sides.

NOTE: Refer to Final Finishing, for drawer front, prior to assembly.

Step 10

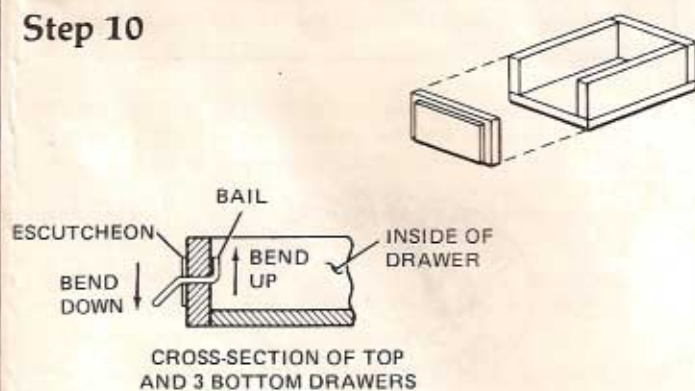

NOTE: Drawer fronts and hardware are installed after all Final Finishing steps are complete.

A. Glue front of each drawer to front edges of sides and bottom.

B. Apply a small amount of white glue to half round escutcheon and glue to front of drawers 2B and 10. Insert knob (brad).

C. Apply a small amount of white glue to the back of key plate and glue to each drawer as indicated in hardware table.

D. Press bail through escutcheon and apply a small amount of white glue to back of plate.

E. Insert handle in previously made holes in drawer front.

F. Bend up protruding ends and bend down front of handle.