

COLLECTORS NO. 40036



Hepplewhite
Serpentine Table

Circa 1780-1800

This table derives its name from the unusual treatment of the edges of its top. The more common of this class of tables had a square edge rectangular top.

In most cases the only ornamentation on these tables was achieved by the use of veneers or inlays. Occasionally beading was used on the edge of the top and around the drawers. The basic material used in the construction, other than fancy veneer, was mahogany.

Primary usage for this table was as a bedside table, but it was also used as an occasional table throughout the house.

This table was also referred to as a lamp stand, and widely used as such after the introduction of the whale oil lamp. Its four legs made it far safer for this use than the tripod-leg candlestands.

This general design was widely copied and other versions of it with two or more drawers or a shelf below the drawers are found in many collections.

INTRODUCTION

BEFORE STARTING

Identify and account for each part by placing it on the Layout Sheet (make sure the correct layout sheet is used when working on multi-kit Instruction Sheets). Should any parts be missing, send a post card to:

THE HOUSE OF MINIATURES
Customer Service - Parts Dept.
2000 Craftmark Center
Statesville, NC 28677-2000

Please print Name, Address, Part Number (Number from Layout Sheet) and Kit Name and Number on card when ordering.

SANDING

Before assembly, sand all the outer surfaces of individual parts with 220 grit sandpaper, or finer, sanded in the same direction as the wood grain until the surface is smooth. Take care not to round any edges or corners of the pieces. Finish sanding with 280 grit sandpaper.

PRE-ASSEMBLY

A. After sanding, check the proper location and fit of each part by assembling parts loosely, without gluing. Use the **DETAIL VIEWS** as a guide.

B. All parts for X-ACTO kits are made on precision milling machines. When adjustments are required, sand to fit.

ASSEMBLY AND FINISHING INSTRUCTIONS



AUTHENTIC REPRODUCTIONS IN MINIATURE

The X-ACTO® House of Miniatures Collectors Series® of furniture and accessories have all been carefully researched by specialists through major museum and library collections to assure the highest quality of authenticity in reproduction. Details are extraordinarily accurate to satisfy the most discriminating miniaturist.

All wood parts are machined to assure accurate and precise acceptance of each piece by another.

For a complete catalog of the X-ACTO® HOUSE OF MINIATURES furniture line and accessories, write to:

THE HOUSE OF MINIATURES
Customer Service - Catalog Dept.
80 Newbridge Road
Bergenfield, NJ 07621

TOOLS AND MATERIALS

A. The following tools will be helpful in constructing this kit:

1. Pin Vise, X-ACTO No. 7144
2. Tweezer, X-ACTO No. 7336
3. Two-inch Sander, X-ACTO 7042
4. Large Clamp, X-ACTO No. 7004
5. Small Clamp, X-ACTO No. 7003
6. X-ACTO Professional Finishing Kit (or equivalent, see note)

B. The following materials will be needed to construct this kit:

1. X-ACTO Tinted Glue (see note)
2. Sandpaper - 220 and 280 grit
3. White glue (or equivalent)
4. Small Artist's Brush

NOTE: The X-ACTO tinted glue is matched to the finish used in the Professional Finishing Kit. This will produce the authentic finish of the period in which the original Furniture was produced. When not using X-ACTO glue follow manufacturer's directions.

GLUING

A. Glue should be applied in small amounts to surface being joined. When gluing dado joints apply glue to dado only.

B. To ensure a tight fit, squeeze excess glue out of the joints. Hold glued parts together with clamps, rubber bands or weights on the parts.

C. Wipe off excess glue promptly.

D. Be sure a glued assembly has dried thoroughly before adding parts.

FINISHING

The X-ACTO Professional Finishing Kit enables you to finish your furniture by the same process used by the professional furniture maker. The end result is what is important — there are easier methods, but none that will give the quality results that this process will. If you use a finish other than X-ACTO's, refer to the manufacturer's directions.

Layout Sheet

KIT 40036

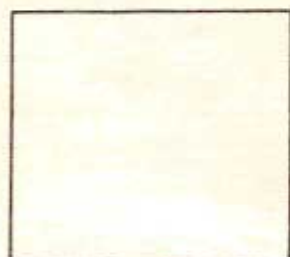

3 (2 REQ'D)

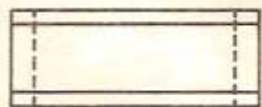

4 (2 REQ'D)

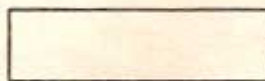

5



7 (4 REQ'D)

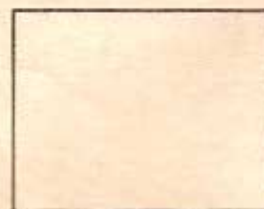

8

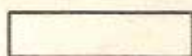

9 (2 REQ'D)

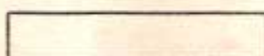

10

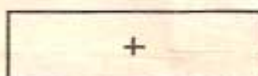

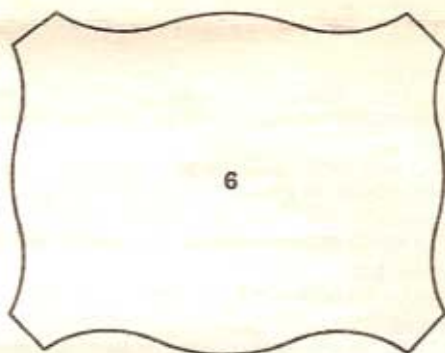

11



6

HARD WARE CHECK LIST

DESCRIPTION	VISUAL DESCRIPTION	QTY
KNOB		1
ESCUTCHEON		1

Step 1

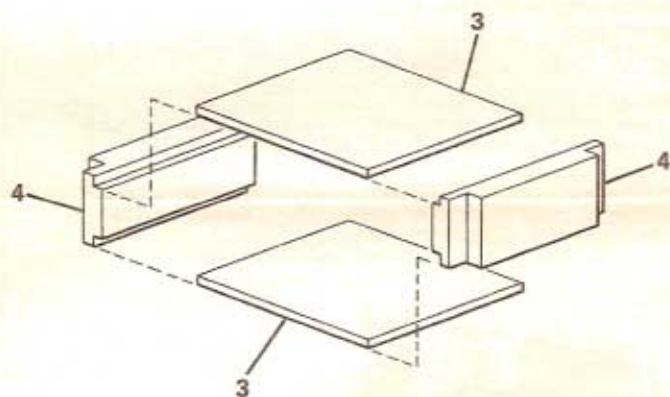

NOTE: Ensure all edges are properly aligned before glue sets.

A. Glue drawer dividers (3) to sides (4). Ensure front and rear edges are flush.

Step 2

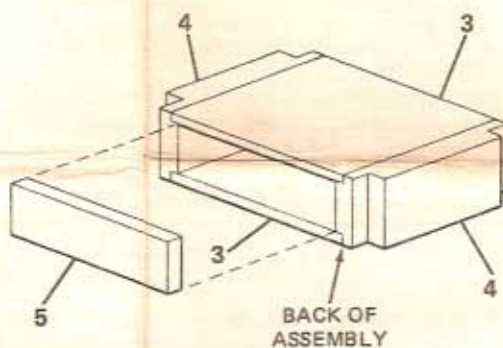

A. Glue back (5) flush with rear edges of sides (4) and drawer dividers (3).

NOTE: Final sanding should be accomplished on assembly at this point.

Detail Views

KIT 40036

Step 3

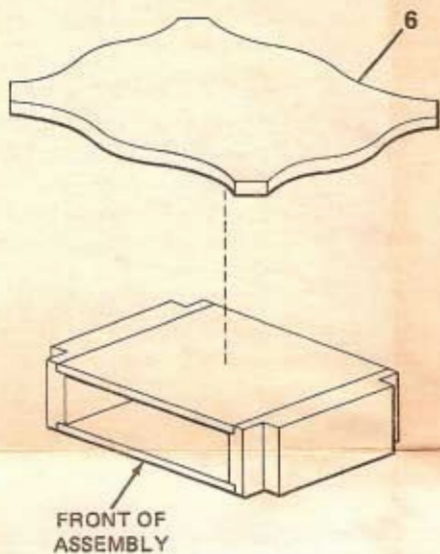

NOTE: Ensure table top is centered on assembly before glue sets.

A. Glue table top (6) to assembly.

Step 4

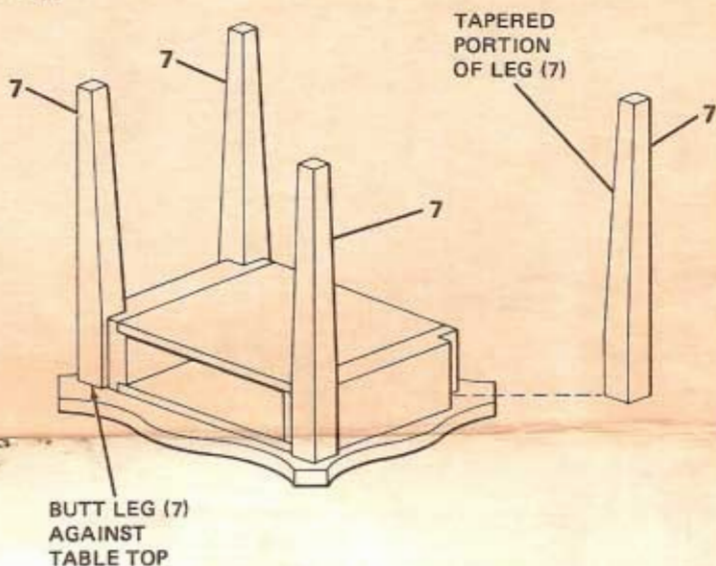

NOTE: Position table top down on a clean flat surface.

The tapered portion of legs face center of table.

A. Glue legs (7) to the four corners. Ensure tapered edge of legs face toward center of table and bottom edge butts against the table top.

Step 5

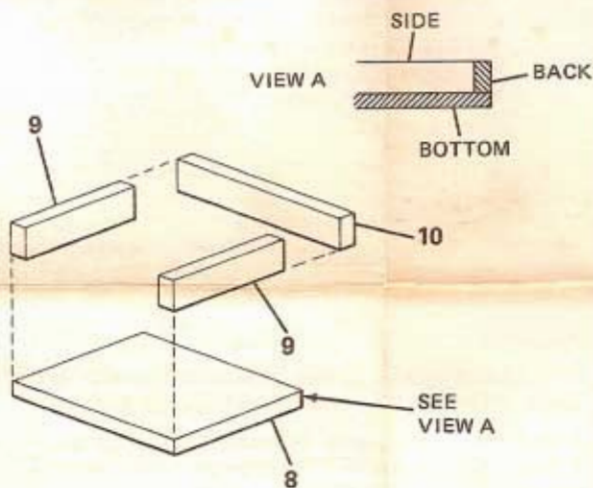

NOTE: Use white glue for assembly of drawer if inside is not going to be stained.

A. Glue drawer sides (9) to bottom (8) making certain they are flush with front edges.

B. Glue back (10) to bottom (8) and against rear edge of sides (9).

C. Mark position of knob on drawer front (11) with a pin using layout sheet as a guide.

D. Drill through hole as marked using a No. 65 drill bit.

NOTE: Refer to Final Finishing for the table and the drawer front.

Step 6

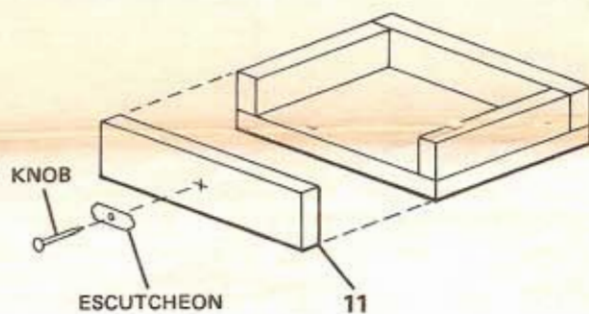

NOTE: Drawer front and hardware are installed after all Final Finishing steps are completed.

A. Glue drawer front (11) to front edges of sides (9) and bottom (8). Ensure edges are flush.

B. Apply a small amount of white glue to escutcheon and glue to drawer front (11). Insert knob (brad).

C. Insert drawer into finished table assembly.