

COLLECTORS NO. 42403

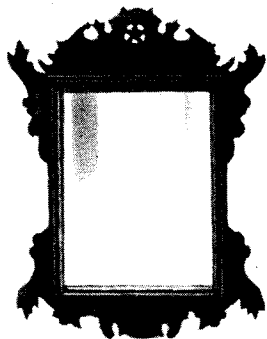

Chippendale
Looking Glass
Circa 1750

Countless versions of this style of looking glass adorned the walls of the colonial homes of America during the 18th century. The outer shapes were typical of the undulating designs that Chippendale favored so much. Many of the frames actually made by Chippendale were asymmetrical in design, but the American cabinetmakers favored more symmetrically balanced designs.

This particular looking glass had a frame made of pine and whitewood covered with a veneer of mahogany. There is a definite distinction, at least a distinction that existed in Colonial America, between mirror and a looking glass. A mirror consisted of any reflective surface, either glass or metal, while a looking glass was always just that, glass.

As the glass making industry grew in America this distinction became less important and both mirrors and looking glasses were made with glass. The modern shopper wouldn't stop to think that there might be a difference.

ASSEMBLY AND FINISHING INSTRUCTIONS



AUTHENTIC REPRODUCTIONS IN MINIATURE

The X-ACTO® House of Miniatures Collectors Series® of furniture and accessories have all been carefully researched by specialists through major museum and library collections to assure the highest quality of authenticity in reproduction. Details are extraordinarily accurate to satisfy the most discriminating miniaturist.

All wood parts are machined to assure accurate and precise acceptance of each piece by another.

For a complete catalog of the X-ACTO® HOUSE OF MINIATURES furniture line and accessories, write to:

X-ACTO® THE HOUSE OF MINIATURES Dept. KIT
45-35 Van Dam Street
Long Island City,
New York 11101

Please include \$2.00 for postage and handling.

INTRODUCTION

BEFORE STARTING

Identify and account for each part by placing it on the Layout Sheet (make sure the correct layout sheet is used when working on multi-kit Instruction Sheets). Should any parts be missing, send a post card to:

X-ACTO/The House of Miniatures
45-35 Van Dam Street
Long Island City, N.Y. 11101

Please print Name, Address, Part Number (Number from Layout Sheet) and Kit Name and Number on card when ordering.

SANDING

Before assembly, sand all the outer surfaces of individual parts with 220 grit sandpaper, or finer, sanded in the same direction as the wood grain until the surface is smooth. Take care not to round any edges or corners of the pieces. Finish sanding with 280 grit sandpaper.

PRE-ASSEMBLY

- A. After sanding, check the proper location and fit of each part by assembling parts loosely, without gluing. Use the **DETAIL VIEWS** as a guide.
- B. All parts for X-ACTO kits are made on precision milling machines. When adjustments are required, sand to fit.

TOOLS AND MATERIALS

A. The following tools will be helpful in constructing this kit:

- 1. One-inch Sander, X-ACTO No. 7041
- 2. X-ACTO Professional Finishing Kit (or equivalent, see note)

B. The following materials will be needed to construct this kit:

- 1. X-ACTO Tinted Glue (see note)
- 2. Waxed paper
- 3. Sandpaper - 220 and 280 grit
- 4. White glue (or equivalent)
- 5. Small Artist's Brush

NOTE: The X-ACTO tinted glue is matched to the finish used in the Professional Finishing Kit. This will produce the authentic finish of the period in which the original Furniture was produced. When not using X-ACTO glue follow manufacturer's directions.

GLUING

- A. Glue should be applied in small amounts to surface being joined. When gluing dado joints apply glue to dado only.
- B. To ensure a tight fit, squeeze excess glue out of the joints. Hold glued parts together with clamps, rubber bands or weights on the parts.
- C. Wipe off excess glue promptly.
- D. Be sure a glued assembly has dried thoroughly before adding parts.

FINISHING

The X-ACTO Professional Finishing Kit enables you to finish your furniture by the same process used by the professional furniture maker. The end result is what is important — there are easier methods, but none that will give the quality results that this process will. If you use a finish other than X-ACTO's, refer to the manufacturer's directions.

Layout Sheet

Kit 42403

Detail Views

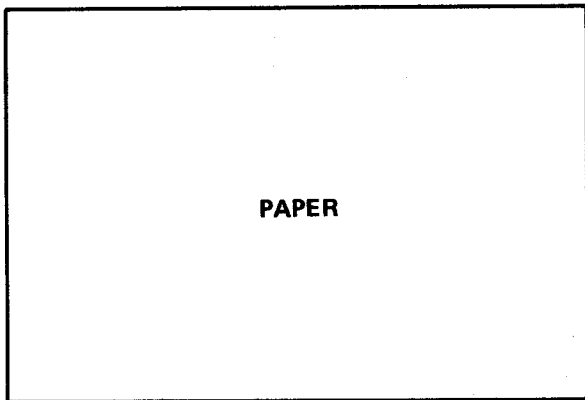
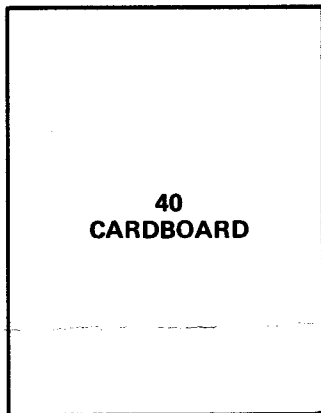
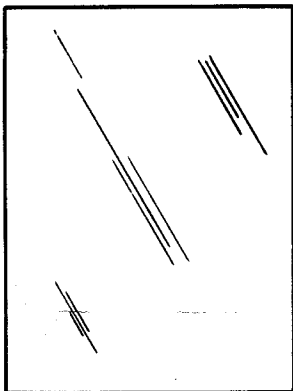
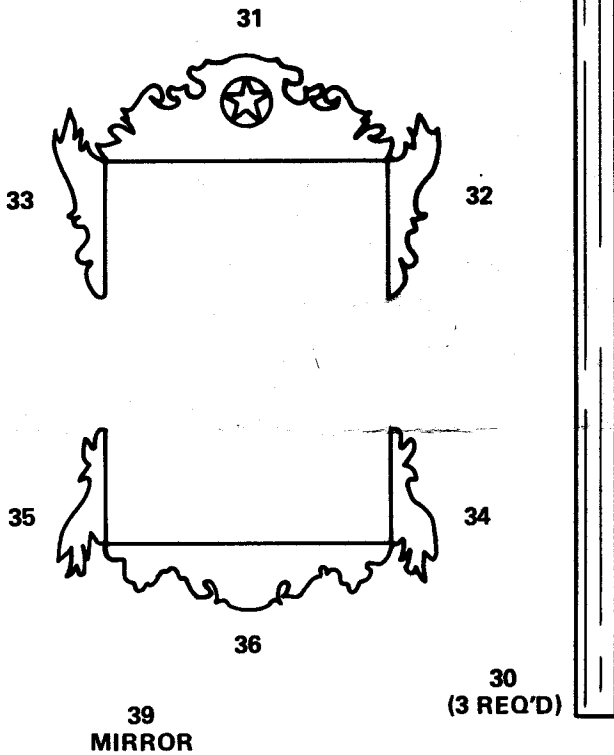

Step 1

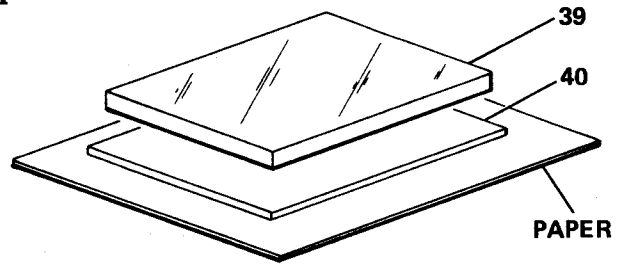

A. Glue mirror (39) to backing (40). Trim backing to exact size of mirror.

B. Glue backing to a piece of plain white paper (not supplied) that is larger than backing. Do not trim.

Step 2

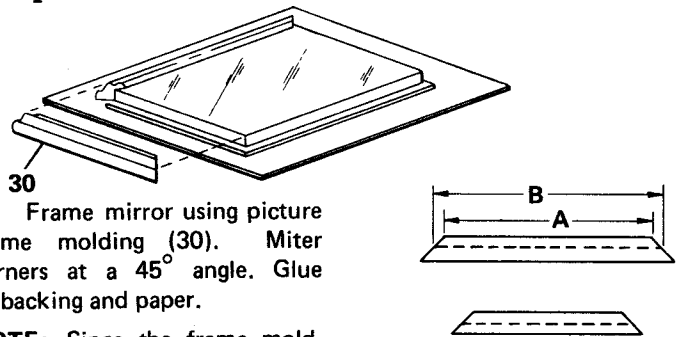

A. Frame mirror using picture frame molding (30). Miter corners at a 45° angle. Glue to backing and paper.

NOTE: Since the frame molding extends over the edge of the mirror, care must be taken when measuring the molding. On the mitering guide, "B" is the length of the mirror edge you are working on.

"A" is the length of the inside edge that will rest on the mirror. "B" less 1/16" will equal "A" with this particular molding regardless of the length of "B".

Step 3

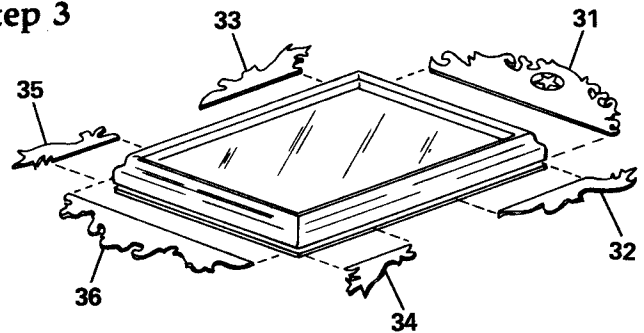

A. Once glue in Step 2 has set, trim paper backing so that you just have a slight reinforcing piece under the trim.

B. Glue on the scrolled frame

as shown. One side of these pieces is not as smooth as the other. In all cases the smooth side should face up. Trim is glued flush with back of mirror. Apply final finish.